

---

## FATIGUE TECHNOLOGY OPERATIONS, MAINTENANCE, AND REPAIR MANUAL

### Big Brute Puller Unit

Part #2720-008, Log #01206  
Revision F

December 7, 2015



Original Instruction

Fatigue Technology Inc. (FTI) is a world-leading aerospace engineering and manufacturing company. FTI pioneered cold expansion technology (which provides solutions to fatigue problems associated with holes in metal structures) back in 1969 and has advanced this science to develop innovative bushing and fastener products. These proprietary products and associated tooling may be covered by patents or agreements owned by or exclusively licensed to Fatigue Technology Inc. Use of tooling procured from other than a licensed source may constitute patent infringement.

The detailed tooling information in this manual was compiled and written by FTI. The tooling was designed specifically for use with FTI's Cold Expansion (Cx™) Systems. FTI cannot be held responsible for damage or injury as a result of operating this equipment if it is used for other than the process intended, with any other tooling not provided by FTI, or not used in accordance with the instructions contained in this manual. To avoid personal injury, please observe all safety precautions and instructions. FTI reserves the right to change specifications or configurations of equipment detailed in this manual as part of our ongoing technical and product improvement programs. If you have any questions about the use or serviceability of this equipment, please contact our Sales Department.

FTI's Cold Expansion™ systems and processes are the subject matter of one or more of the following patents: 5,083,363; 5,096,349; 5,103,548; 5,127,254; 5,129,253; 5,218,854; 5,245,743; 5,305,627; 5,341,559; 5,380,136; 5,405,228; 5,433,100; 5,468,104; 6,077,010; 6,183,180; 6,487,767; 6,792,657; 6,990,722; 7,024,908; 7,100,264; 7,375,277; 7,406,777; 7,448,652; 7,509,829; 7,617,712; 7,641,430; 7,926,318; 7,946,628; 7,958,766; 8,057,144; 8,061,178; 8,069,699; 8,117,885; 8,128,308; 8,191,395; 1,061,276; 513,898; 692015124; 581,385; 69310828; 468,598; 69105390; 643,231; 69414946; 696,686; 785,366; 1032769; 1893875; 2019739; 1280621; 4819678; and other patents pending. These systems and processes are tooling critical and must be performed in accordance with FTI's specifications or controlling documents. To ensure proper results from FTI's cold expansion systems and to be licensed to use FTI's patented processes, it is essential that FTI's complete integrated system of tooling be purchased and utilized. The use of tooling purchased from other than a licensed supplier could jeopardize fatigue life enhancement and may constitute patent infringement.

FTI reserves the right to change the specifications or configurations of tooling detailed in this manual as part of its ongoing technical and product information program. Should inconsistencies occur between your tooling and this manual, please contact our Sales Department.

### ***ABOUT FATIGUE TECHNOLOGY INC.***

Fatigue Technology Inc. (FTI) has provided innovative solutions to fatigue problems in metal structures since 1969. Complete systems of tooling are used worldwide to enhance the fatigue life of holes in airframes, turbine engines, and other critical structures.

The FTI staff of professionals provides a full range of support services including:

- Application engineering
- Detailed project planning, implementation, and management
- On-site assistance, including training and tool room setup

The Sales Department is always available to assist with special fatigue enhancement requirements. Please contact FTI with questions at any time.

## TABLE OF CONTENTS

SECTION	DESCRIPTION	PAGE
1.0	Introduction.....	1
1.1	About the Big Brute Puller Unit.....	1
1.2	General Specifications.....	2
1.3	General Description.....	3
2.0	Safety.....	5
3.0	Puller Unit Operating Instructions.....	7
3.1	Puller Unit Setup and Operation Procedure.....	7
3.2	Actuation of the Puller.....	7
4.0	Maintenance.....	8
4.1	General Cleaning.....	8
4.2	Lubrication.....	8
4.3	Inspection.....	8
4.4	Assembly and Disassembly.....	8
4.5	Chuck Assembly Cleaning and Jaw Replacement.....	10
5.0	Troubleshooting.....	11
5.1	PowerPak Will Not Build Full Hydraulic Pressure.....	11
5.2	Puller Retracts on First Trigger Actuation, But Will Not Return to Start Position.....	12
5.3	PowerPak Will Not Generate Constant Pressure (or Hiccups).....	13
5.4	PowerPak Will Not Operate or Maintain Sufficient Pressure (6,000 psi).....	13
5.5	Mandrel Sticks in Hole When Puller Activated.....	14
6.0	Illustrated Parts Breakdown.....	15
6.1	Big Brute Trigger Rework Kit (FTI-CT-RK <i>and</i> BB-CT-RK).....	16
6.2	Big Brute Seal Kit (BB-SK).....	17
6.3	Previous Trigger Assembly.....	18
6.4	Big Brute Parts List.....	19
E.C.	Declaration of Conformity.....	21

## TABLE OF CONTENTS (Continued)

<b>SECTION</b>	<b>DESCRIPTION</b>	<b>PAGE</b>
<b>FIGURES</b>		
Figure 1.3-1	Big Brute Puller Unit .....	3
Figure 1.3-2	Big Brute Puller Unit Specifications.....	4
Figure 2.0-1	Safety Stickers .....	5
Figure 2.0-2	Location of Air Disconnect.....	5
Figure 4.5-1	Chuck Assembly .....	10
Figure 5.1-1	FT-200 PowerPak .....	11
Figure 5.2-1	Hydraulic Quick Coupler (FT-200) .....	12
Figure 5.2-2	Location of Hydraulic Quick Coupler (FT-20).....	12
Figure 5.2-3	Enerpac CT-604 Pressure Relief Tool .....	12
Figure 5.3-1	Location of Trigger Response Valve (FT-200).....	13
Figure 5.4-1	Pressure Gage (FT-200).....	13
Figure 6.1-1	Diagram of Cartridge Trigger Assembly .....	16
Figure 6.3-1	Diagram of Previous Trigger Assembly .....	18
Figure 6.4-1	Assembly Diagram.....	20
<b>TABLES</b>		
Table 1.3-1	Big Brute Specifications .....	4
Table 6.1-1	Big Brute Trigger Rework Kit .....	16
Table 6.2-1	Big Brute Seal Kit (BB-SK) .....	17
Table 6.3-1	Parts List for Previous Trigger Assembly.....	18
Table 6.4-1	Big Brute Parts List.....	19

## SECTION 1.0: INTRODUCTION

---

This instruction manual contains information on the operation and maintenance of the Big Brute Puller Unit. To obtain optimum performance and many years of trouble-free service, operate the puller unit properly and carefully follow maintenance procedures. **Read this manual before operating the puller unit** and retain the manual for future reference. If requested, FTI will provide this manual in the language of the end-user.

### 1.1 ABOUT THE BIG BRUTE PULLER UNIT

The Big Brute (BB) hydraulic puller unit is a powerful, heavy-duty tool specifically designed for use with FTI's patented Split Sleeve Cold Expansion™ process. The BB puller unit is designed to pull a mandrel through a hole with the pre-lubricated stainless steel split sleeves used in this process.

BB puller units have a maximum pull force of 38,000 pounds at 10,000 psi pump pressure. The BB is available in sizes (models) capable of cold expanding holes up to 1-3/4 inches in diameter and 10 inches deep in aluminum, steel, and titanium. For hole sizes larger than 1-3/4 inches, please contact the FTI technical support staff for assistance.

The Big Brute is available in various models to accommodate multiple material stackups, hose options, and mandrel adapters. See the "Reference Information" column in Table 6.4-1 for each variant:

BB-xx, where '-xx' relates to material stack (see Table 1.3-1)

BB-xx-V, where '-V' represents high visibility hoses

BB-xx-Hxx, where '-Hxx' represents a unique hose length other than the standard 10 feet

BB-xxA, which comes with threaded mandrel adapters:

7/8-inch BB-A-D35

1-inch BB-B-D35

1-inch BB-C-D35

BB-xxB, which comes with a BB-CA-16 chuck mandrel adapter

BB-xxC, which comes with 20-foot hoses

BB-RR and BB-RT, which are designed for the railroad industry and are shorter in length

The Big Brute has a fail-safe air control system that causes the puller retraction cycle to be interrupted whenever the operator releases finger pressure on the trigger or in the event of air or hydraulic hose failure. All puller units operate in conjunction with either of FTI's PowerPak air-hydraulic power units, the standard FT-200 or portable FT-20 (and are compatible with older units IW100MF and IW10MF). The Big Brute has proven to be very reliable and requires minimal maintenance.

## 1.2 GENERAL SPECIFICATIONS

Pull Force Capacity.....	38,000 pounds
Air Line Requirements.....	3/8-inch to 1/2-inch inside diameter
Air Flow Requirements (via PowerPak) .....	45 cfm
Weight:*	
BB-30.....	33 pounds (15.3 kg)
BB-70.....	40 pounds (18.15 kg)
BB-100.....	45 pounds (20.5 kg)
BB-RR .....	30 pounds (13.6 kg)
BB-RT.....	30 pounds (13.6 kg)
Stackup Capacity:	
BB-30.....	3.0 inches (76.2 mm)
BB-70.....	7.0 inches (177.8 mm)
BB-100.....	10.0 inches (254 mm)
BB-RR .....	0.90 inches (22.86 mm)
BB-RT.....	0.90 inches (22.86 mm)
Hole Diameter Capacity:	
Aluminum .....	up to 1-3/4 inches diameter
Steel .....	up to 1-3/4 inches diameter
Titanium.....	up to 1-3/4 inches diameter
Actuation / Operation.....	Pneumatic / Hydraulic
Air and Hydraulic Hose Length .....	10 feet (3 meters)
Compatible PowerPaks .....	FT-200 or FT-20
Fail-Safe.....	Air logic safety circuit halts mandrel retraction when trigger is released
Replacement Seal Kit.....	BB Seal Kit (BB-SK)

\*A user supplied suspension system might be required at the end use site. The requirement for a suspension system is based on the end user's workplace lifting and weight standards. A risk analysis for the suspension is necessary to maintain compliance to end user's standards or directives. All risks involved with the suspension of the Big Brute are the responsibility of the end user. User instructions and training regarding the suspension system are the responsibility of the end user.

### 1.3 GENERAL DESCRIPTION

- Air actuated, hydraulic puller is designed to pull a mandrel through a hole using the pre-lubricated stainless steel split sleeves used in the cold expansion process.
- Maximum pull force is 38,000 pounds at 10,000 psi of hydraulic pressure.
- Includes a 10-foot hose assembly, spanner wrench, and nose cap pin wrench.
- Capable of cold expanding holes up to 2.5 inches in aluminum and mild steel and 1.25 inches in titanium and high strength steel.
- Up to 10.0 inches material stackup capacity.
- Hydraulic pressure provided by the FT-200 PowerPak.

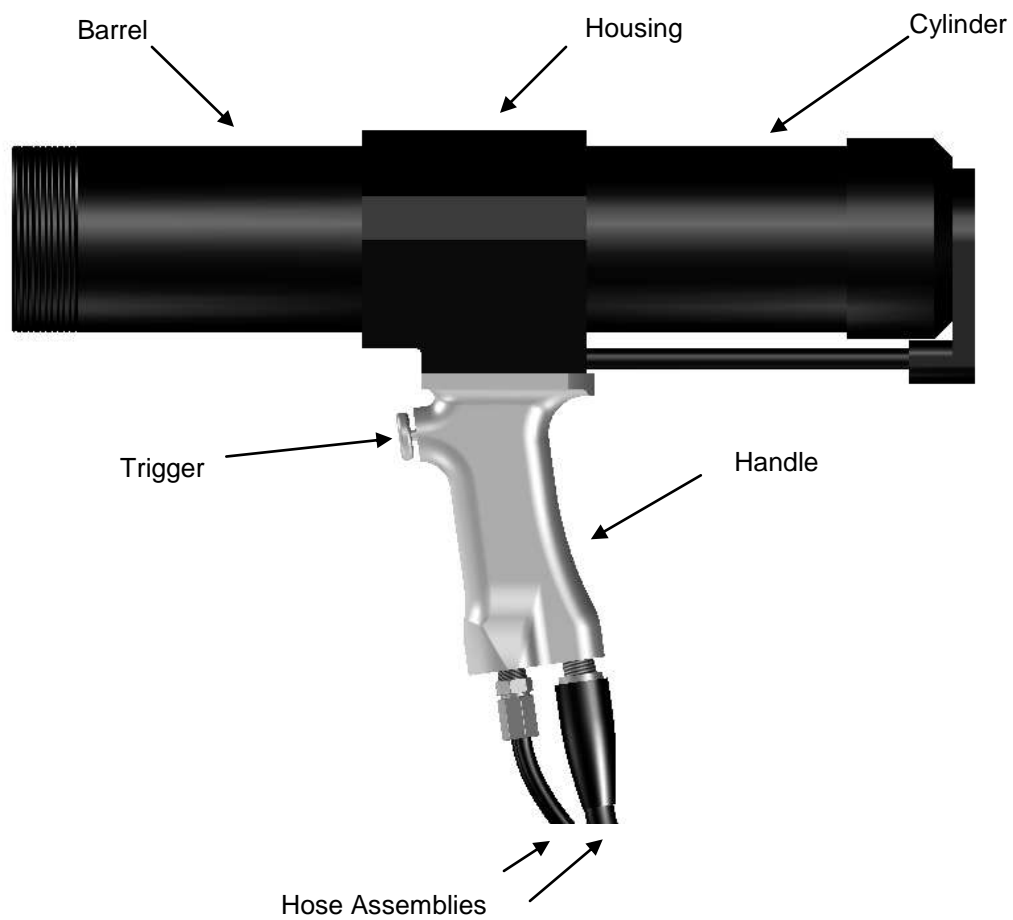

**Figure 1.3-1  
Big Brute Puller Unit**

**Table 1.3-1  
Big Brute Specifications**

Model Number	Maximum Material Stackup (inch)	L (Reference FTI Tooling Catalog) (inch)	F (Reference FTI Tooling Catalog) (inch)	Weight (lbs)	Mandrel Attachment	Stroke (inch)
BB-30	3.0	21.3	10.5	35	0.960-inch tang 7/8-14 thd	6.26
BB-30A	3.0	21.3	10.5	35	7/8-14 thd 1-14 thd	6.26
BB-70	7.0	27.0	13.4	40	0.960-inch tang 7/8-14 thd	9.14
BB-70A	7.0	27.0	13.4	40	7/8-14 thd 1-14 thd	9.14
BB-RR	0.9	14.9	7.0	30	ø.876 tang	2.89
BB-RT	0.9	15.4	7.5	30	ø.876 tang	2.89
BB-100	10.0	35.3	17.5	45	7/8-14 thd	13.26

**Nosecap Selection:** The Big Brute Puller Unit is compatible with flush nose caps and extension nose caps (see Section 2 of the FTI Tooling Catalog).

**Mandrel Selection:** The Big Brute Puller Unit is directly compatible with threaded or tang mandrels (see Section 2 of the FTI Tooling Catalog).

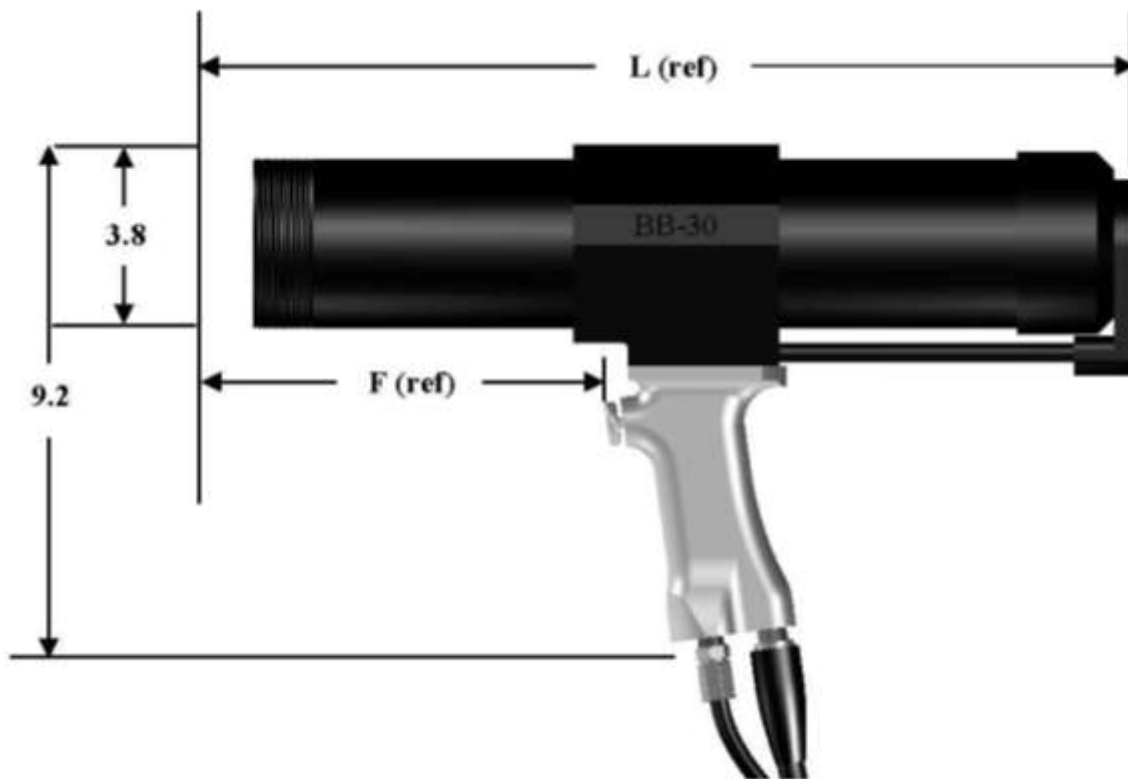

**Figure 1.3-2  
Big Brute Puller Unit Specifications**



## SECTION 2.0: SAFETY

---

Consult the PowerPak manual for safety precautions before connecting the puller unit.

When used in accordance with these instructions, the puller unit is safe and easy to use. All general safety precautions associated with hydraulic and pneumatically operated power tools should be observed. Many of these are noted in this section. Ultimately, the operator is responsible for personal safety; however, the following general safety precautions should be observed.

1. **CAUTION:** The weight of this unit may require a suspension system per the end-user's workplace lifting standards.
2. Wear eye and ear protection when operating the puller unit.

*Read manual before using*

*Always wear eye protection*

*Always wear ear protection*



**Figure 2.0-1  
Safety Stickers**

3. Disconnect the air supply when:
  - Maintenance is to be performed.
  - Hydraulic hose is disconnected.
  - PowerPak is not in use.
4. In the event of a ruptured or leaking hydraulic hose, **IMMEDIATELY RELEASE THE TRIGGER AND DISCONNECT THE AIR LINE**, at the air coupler, from the PowerPak (see Figure 2.0-1). **Never use your hands** to grasp a leaking hose under pressure. The force of escaping hydraulic fluid could cause serious injury. If hydraulic oil should penetrate the skin, medical attention must be sought immediately.
5. Keep hands away from the noscap assembly when actuating the puller unit.
6. Release the puller unit trigger when the mandrel clears the workpiece, or becomes stuck.



**Figure 2.0-2  
Location of Air Disconnect**

7. The end cap must always be in place while in use. Injury may occur if the end cap is removed during operation. All new puller units have been modified to ensure operator safety. However, rework instructions are available from FTI for any Big Brute puller units that do not have a role pin and air seal adapter like that shown in Figure 6.3-1.
8. Before operating the pump, tighten all hose connections using the proper tools. Do not overtighten the connections. Connections need only be tightened securely and leak-free. Overtightening may cause premature thread failure or high-pressure fittings to split at pressures lower than their rated capacities.
9. Operators must read this manual in its entirety before using the Big Brute. Eye and ear protection must be worn while operating the Big Brute. Three safety stickers on the Big Brute act as a reminder to these instructions. The symbols are defined in Figure 2.0-1.
10. Do not use in potentially explosive atmospheres.

### **Hydraulic Hose Safety**

11. Inspect the hydraulic hose for signs of wear (cuts, abrasions, or kinks) to the outer shell materials. Pump clean oil through the entire length. Pressurize the hose and check for leaks at the crimped connectors, between the hose material and the fitting, and between the fitting and the coupler.
12. **DO NOT** attempt to disconnect the hydraulic hose while it is under pressure.
13. **DO NOT** expose hoses to potential hazards such as extreme heat or cold, sharp surfaces, or heavy impact.
14. **DO NOT** allow hoses to kink, twist, curl, or bend so tightly that the oil flow within the hose is blocked or reduced. Periodically inspect the hose and fittings for wear or damage that could cause premature failure of the hose or fittings and possibly result in injury. Damaged hoses must be replaced immediately.
15. **DO NOT** use the hose to move attached equipment.
16. **DO NOT** remove strain reliever from hoses.
17. Hose strain relievers must be placed around hose fittings during use. Hoses with damaged strain relievers must be replaced immediately.
18. Hose material and coupler seals must be compatible with hydraulic fluid that meets the requirements of U.S. MIL-SPEC #5606.
19. Hoses must not come in contact with toxic materials such as creosote-impregnated objects and some paints. Keep couplers and hoses clean and free of paint. Hose deterioration due to chemical degradation may cause the hose to fail under pressure. Damaged hoses must be replaced immediately.
20. Before operating pump, make sure all hose connections are tightened securely. **DO NOT** overtighten.
21. If hoses require replacement, contact FTI Sales Department.

**IMPORTANT:** FTI completed a risk assessment on this unit at our factory. Any modifications done by a third party or the final user are excluded from that risk assessment. As a result, modifications done by a third party or the final user nullify the CE marking.

## SECTION 3.0: PULLER UNIT OPERATING INSTRUCTIONS

---

Become familiar with these instructions before operating the puller.

### 3.1 PULLER UNIT SETUP AND OPERATION PROCEDURE

Refer to Section 6.0 (Illustrated Parts Breakdown) for parts identification.

1. Inspect all threads and fittings of PowerPak for signs of wear or damage and replace them if necessary.
2. Uncoil the hose assembly of the puller unit and inspect all threads, couplings, and hoses for damage and degradation.
3. Remove the thread protectors from the hydraulic fittings and thread the hydraulic hose fitting from the puller unit (female) onto the hydraulic fitting of the FTI PowerPak (male). Wipe fittings clean prior to connecting. Make sure to thread couplers completely together. There should be positive contact between the PowerPak coupler and the hose fitting flange. Failure to completely tighten the coupler will prevent the puller from returning to the forward (start) position. See Section 5.0, Problem 5.2, for more information.
4. Connect the male/female AIR quick-disconnects from the puller unit to the PowerPak.
5. Remove the thread protectors from the air inlet on back of the PowerPak. Connect the female quick disconnect of a 3/8-inch or 1/2-inch (9.5 mm or 12.7 mm) inner diameter shop air line onto the male air inlet of the PowerPak.
6. Test the shop air supply to ensure that air is clean, dry, and between 90 and 120 psi (6.2 and 8.3 bar) at 45 cfm (1274.3 liter/minute).
7. Install the appropriate mandrel into the threaded adapter (hand tight).
8. Install the appropriate nosecap assembly over the mandrel and thread onto the barrel (hand tight).

### 3.2 ACTUATION OF THE PULLER

1. The puller can be activated only when connected to a FTI PowerPak.
2. Activate the puller by depressing the trigger on the handle. Hydraulic pressure is transmitted through the hose to the cylinder of the puller which then retracts the hydraulic piston.
3. Releasing the trigger changes pressure at the pilot valve and stops the pull cycle, and returns puller to original position.
4. If the puller fails to operate as detailed above, refer to Section 5.0 (Troubleshooting).

## SECTION 4.0: MAINTENANCE

---

The puller unit requires routine checking and periodic preventative maintenance to ensure safe, trouble-free operation. No special maintenance is required. The following maintenance actions are suggested.

**WARNING**  
**Disconnect the PowerPak from the air supply before performing maintenance or repair procedures.**

### 4.1 GENERAL CLEANING

1. Periodically clean the outer surfaces of the puller unit and PowerPak.
2. When not in use, ensure thread protectors are reinstalled.
3. Keep all hose connections free of dirt and grime.

### 4.2 LUBRICATION

1. There is no internal lubrication requirement for the puller unit.
2. Whenever the puller is to be stored for any length of time, maintain a thin coat of 10-weight oil on the outside of black oxidized surfaces.

### 4.3 INSPECTION

Periodically inspect the threaded fittings for cracks, leaks, or other damage. Repair and replace as necessary.

### 4.4 ASSEMBLY AND DISASSEMBLY

Normal replacement of seals (refer to the Illustrated Parts Breakdown, Figure 6.4-1).

#### Disassembly

1. Loosen the lock ring (14) and remove the nose cap (13).
2. Remove the Allen-head bolt (19) and pull out the barrel (5).
3. Loosen the locknut (9) and unthread the chuck or threaded adapter.
4. Remove the set screws (27), air adapter (11), and air tube.
5. Remove and replace the seals (20) at each end of air tube.
6. Loosen the lock rings (14), and unthread the end cap (29) and cylinder (3).

7. Pull the cylinder (3) off the piston (4) (the piston may stick in the cylinder). If needed, remove the piston from the cylinder after the cylinder is removed.
8. Remove and replace the O-rings (25) on the piston (4).
9. Remove the handle (16) by removing the Allen screws (12).
10. Pull the hydraulic adapter (3) out of the handle or housing (8), whichever it is stuck in.
11. Remove and replace the O-ring (13) and backup ring (11) at each end of the hydraulic adapter.
12. Remove the sleeve (2).
13. Remove and replace the O-ring (24) and backup ring (25).
14. Remove and replace the O-ring (22) and backup ring (23).
15. Remove and replace the scraper (21).

### **Reassembly**

1. Replace the sleeve (2).
2. Install the piston (4) in the barrel (3).
3. Put the sleeve (2) onto the piston shaft (3) and slide the sleeve down to end of the barrel so the O-rings (25) are seated down in the end of the cylinder.
4. Thread the barrel and sleeve into the housing (8).
5. Align the sleeve, replace the hydraulic adapter (3) in the handle (16), replace the gasket (14), and install the handle.
6. Thread the end cap (29) onto end of the barrel and tighten the lock rings (14).
7. Install the locknut (9) and chuck on the threaded adapter and tighten the locknut.
8. Replace the barrel and Allen bolt (19).
9. Install the nosecap (13) and lock ring.

#### 4.5 CHUCK ASSEMBLY CLEANING AND JAW REPLACEMENT

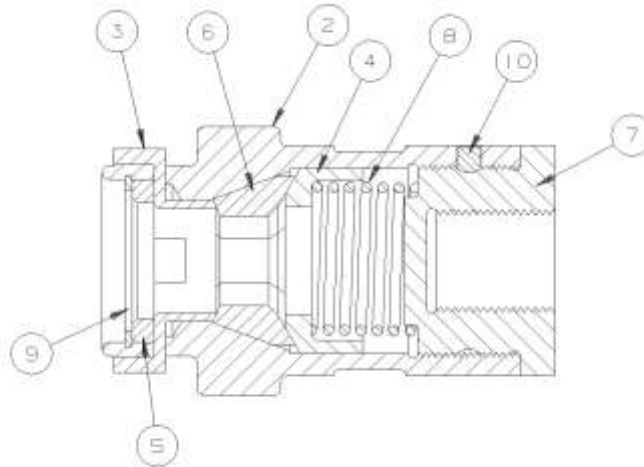

Detail Number	Name of Detail	BB-CA-11 Part Number	BB-CA-16 Part Number	BB-CA-20 Part Number
10	Set Screw		1045-109	
9	Retaining Ring		1045-115	
8	Spring		1005-005	
7	Chuck Adapter		2314-001	
6	Jaws	2309-003	2309-001	2309-002
5	Retainer Ring		2308-001	
4	Jaw Follower		2307-001	
3	Jaw Release		2306-001	
2	Casing		2315-001	

**Figure 4.5-1  
Chuck Assembly**

1. Unscrew the chuck adapter (7) from the casing (2) with a counterclockwise motion. Care should be taken not to lose the spring (8), jaws (6), or follower (4) out of the end of the unit.
2. Remove the spring (8), follower (4), and jaws (6).
3. Clean the casing (2), jaws (6), release (3), and retainer (9) as a unit in any solvent that leaves little residue.
4. Replace any damaged jaws.
5. Place the chuck assembly in a vertical position with the nose down. In this position, align the jaws around the release (3).

**Note: Do not use grease or oil in reassembling the unit. Debris has a tendency to accumulate, preventing proper operation.**

## SECTION 5.0: TROUBLESHOOTING

This section provides solutions to some basic trouble spots. If you cannot solve your maintenance or operational problems with the information provided in this section, contact the nearest FTI representative.

**Note: Should difficulties originate in the PowerPak, consult the specific PowerPak's Operations, Maintenance, and Repair Manual.**

<u>PROBLEM</u>	<u>CAUSE</u>	<u>SOLUTION</u>
----------------	--------------	-----------------

### 5.1 POWERPAK WILL NOT BUILD FULL HYDRAULIC PRESSURE

- |  |  |
|--|--|
| (a) One or more of the key air or hydraulic lines has not been securely connected. | (a) Check the following hose connections (see Figure 5.1-1 for hose couplers): <ol style="list-style-type: none"><li>1. Male air line quick-disconnect fitting from shop air system to PowerPak</li><li>2. Hydraulic quick couplings connecting the hoses to the PowerPak manifold, and the puller to the hydraulic hoses</li><li>3. Two male/female air line quick-disconnect fittings connecting the puller to the PowerPak manifold</li><li>4. Check that the main air supply has not been interrupted.</li></ol> |
|--|--|

#### CAUTION

Hydraulic oil under extreme pressure may cause serious injuries if not handled carefully. For technical assistance, please contact the FTI Sales Department.

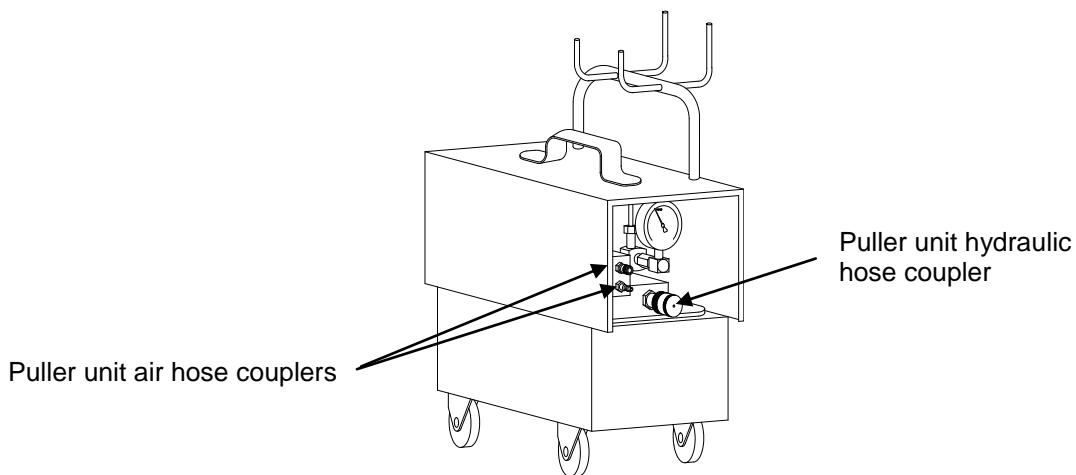

**Figure 5.1-1  
FT-200 PowerPak\***

\*Drawings not to scale.

**PROBLEM**

**CAUSE**

**SOLUTION**

**5.2 PULLER RETRACTS ON FIRST TRIGGER ACTUATION, BUT WILL NOT RETURN TO START POSITION**

- |   |   |  |
|---|---|--|
| <p>(b) As above, AND the hydraulic hose is difficult to bend or coil (indicating unrelieved pressure built up in the hose).</p> | <p>(a) The new puller unit requires lubrication through the piston and cylinder.<br/>(b) The hydraulic quick coupler line has not been completely tightened at the PowerPak manifold (there should be no space between the PowerPak coupler and the hose fitting flange).</p> | <p>(a) Cycle trigger several times to introduce hydraulic fluid into the cylinder.<br/>(b) Once hydraulic pressure has been introduced to the hydraulic hose, the pressure must be relieved before the coupler can be sufficiently tightened. See Figures 5.2-1 and 5.2-2.</p> |
|---|---|--|

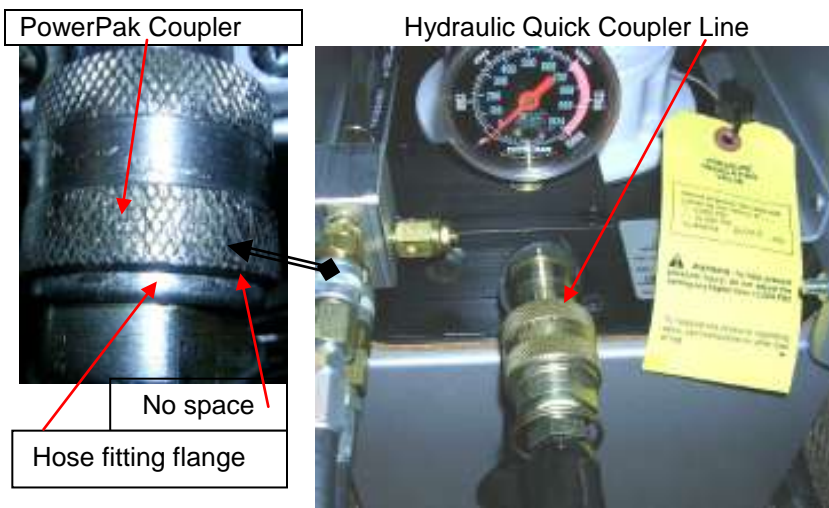

**Figure 5.2-1  
Hydraulic Quick Coupler (FT-200)**

Procedure for relieving hydraulic pressure:

1. Disconnect main air supply.
2. Disconnect coupler from the PowerPak.
3. Connect Enerpac CT-604 to the coupler and bleed off hydraulic oil to relieve the built-up pressure. The Enerpac CT-604w Pressure Relief Tool is shown in Figure 5.2-3.
4. Once pressure is relieved, the coupler may be tightened and reinstalled onto the PowerPak.
5. Re-attach air lines to get puller to return.
6. Check oil level in PowerPak reservoir.

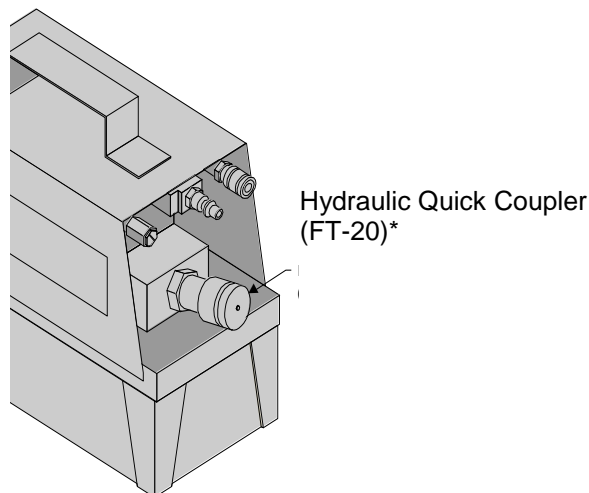

**Figure 5.2-2  
Location of Hydraulic Quick Coupler (FT-20)**



**Figure 5.2-3  
Enerpac CT-604 Pressure Relief Tool**

\*Drawings not to scale.



**PROBLEM**

**CAUSE**

**SOLUTION**

**5.3 POWERPAK WILL NOT GENERATE CONSTANT PRESSURE (OR HICCUPS)**

- (a) Trigger response valve requires adjustment.
- (a) Adjustment procedure:

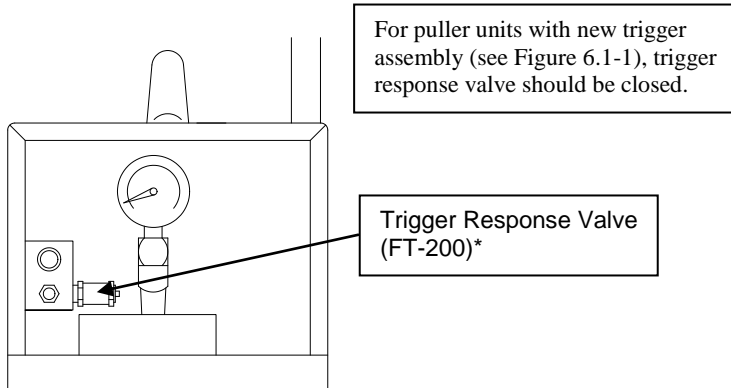

**Figure 5.3-1  
Location of Trigger Response Valve (FT-200)**

1. Loosen the locknut on the trigger response valve (Figure 5.3-1).
2. Using a screwdriver, open the screw counterclockwise until the PowerPak will not start when puller trigger is depressed.
3. Turn screw clockwise until:
  - PowerPak generates constant pressure when puller triggers is depressed, and
  - PowerPak starts instantly when puller trigger is depressed and stops instantly when released. When the puller trigger is depressed, the PowerPak should be run at the pre-set pressure until the trigger is released.
4. Hold the set screw in position and tighten the locknut.

**5.4 POWERPAK WILL NOT OPERATE OR MAINTAIN SUFFICIENT PRESSURE (6,000 PSI)**

- (a) Hydraulic pressure requires adjusting (applicable to FT-200 PowerPak only).

- (a) Adjust PowerPak pressure valve:

1. Squeeze the trigger on the puller unit to activate the PowerPak.
2. If pressure does not reach 6,000 psi, loosen the wingnut and turn hydraulic pressure control clockwise until pressure reaches 6,000 psi.
3. Tighten locknut to secure available shop air.

- (b) Inadequate air supply.

- (b) Increase pressure or flow of available shop air.

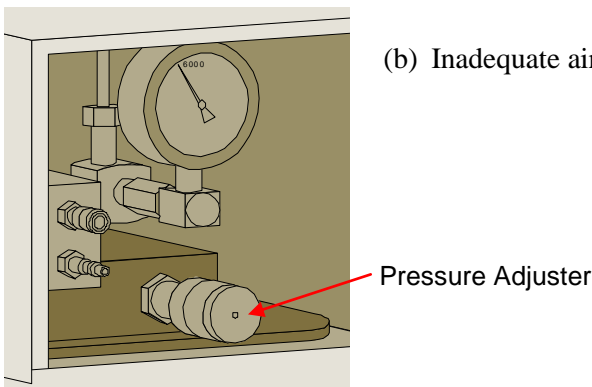

**Figure 5.4-1  
Pressure Gage (FT-200)**

If the PowerPak will not generate or maintain sufficient pressure, the main air line pressure is too low or the PowerPak hydraulic pressure requires adjustment. See Figure 5.4-1 for location.

<p>Air pressure requirements: 1/2-inch inside diameter air line with 90 to 120 psi for the FT-200</p> <p>Air flow requirements: 40 to 50 cfm for the FT-200</p>
---

\*Drawings not to scale.

**PROBLEM**

**CAUSE**

**SOLUTION**

**5.5 MANDREL STICKS IN HOLE WHEN PULLER ACTIVATED**

(a) Not enough pressure used to generate pull forces.

(a) Use the following procedure to analyze the problem:

1. Actuate the puller unit and observe pressure reading on the PowerPak pressure gage (FT-200 PowerPak only).
2. Pressure gage should read 6,000 psi. If an increase in pressure is required, refer to the solution for Problem 5.4 in this section for instructions.
3. Actuate the puller again. If the mandrel remains stuck, increase pressure to 10,000 psi.
4. If the mandrel remains stuck at 10,000 psi, immediately disengage the mandrel from the puller unit. Push the mandrel out using an impact hammer. Contact the FTI Sales Department for additional assistance.

## **SECTION 6.0: ILLUSTRATED PARTS BREAKDOWN**

---

FTI has redesigned the puller unit trigger assembly. Puller units with serial number 0555 or higher have the new cartridge trigger assembly design. The new design will reduce the occurrence of trigger air leaks, perform more reliably (better pump actuation), and be easier to maintain.

The previous trigger design detailed in Section 6.3 can be easily replaced with this improved trigger assembly detailed in Section 6.1. Two part numbers are needed for replacement:

- Either the Cartridge Trigger Assembly Kit (FTI-CT-RK) or the Big Brute Rework Kit (BB-CT-RK) – see kit differences in Section 6.1.
- Puller Trigger Rework Tool Kit (FTI-CT-RKT)

One FTI-CT-RK or BB-CT-RK kit is required for each puller unit converted. Only one FTI-CT-RKT is required regardless of the number of puller units converted. The FTI-CT-RKT kit includes the tools (punch, tap, etc.) required and detailed instructions on how to perform the modification.

The trigger assembly conversion consists of FTI part numbers 2318-001 through -012. Models with serial numbers less than 0555 have the old trigger assembly. This includes the following models: BB-RR, BB-30, BB-70, BB-100, BB-30A, BB-70A, BB-30B, BB-70B, BB-30C, BB-RT, BB-30-H25, BB-30A-H25, and BB-30-737.

**6.1 BIG BRUTE TRIGGER REWORK KIT (FTI-CT-RK and BB-CT-RK)**

This kit is used to repair or refurbish older puller units. Table 6.1-1 is a parts list for the Big Brute Rework Kit and Figure 6.1-1 shows a diagram of the cartridge assembly.

**Table 6.1-1  
Big Brute Trigger Rework Kit**

Quantity	Piece Number	Description	FTI Part Number	Contained Inside Kit
4	Not Pictured	Screw, SHC (10-32 UNFX 3/4)	1035-005	BB-CT-RK
1	Not Pictured	BB-H-D16 Hydraulic Adapter	2039-003	BB-CT-RK
1	Not Pictured	Adapter, Air	2324-001	BB-CT-RK
1	See Section 6.2	Big Brute Seal Kit (BB-SK)	8000-486	BB-CT-RK
1	1	Valve, Cartridge	1187-622	BB-CT-RK and FTI-CT-RK
1	2	Push Button, Brass	1187-623	BB-CT-RK and FTI-CT-RK
1	3	Retaining Ring, Internal	1187-624	BB-CT-RK and FTI-CT-RK
1	4	Sleeve, Puller Handle Trigger	3196-001	BB-CT-RK and FTI-CT-RK

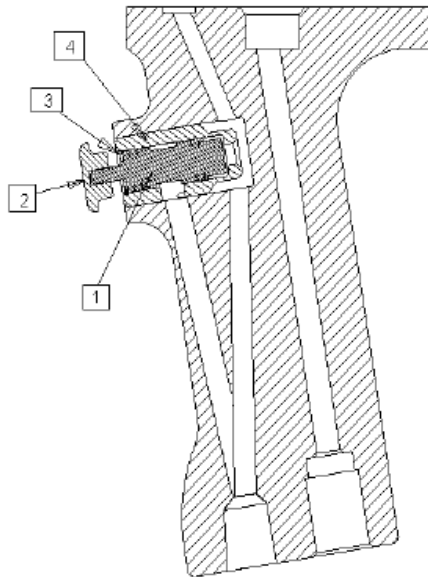

**Figure 6.1-1  
Diagram of Cartridge Trigger Assembly**

**6.2 BIG BRUTE SEAL KIT (BB-SK)**

This kit is used to replace seals. It is included as part of the Big Brute Rework Kit (see Section 6.1). Table 6.2-1 is a parts list for the Big Brute Seal Kit.

**Table 6.2-1  
Big Brute Seal Kit (BB-SK)**

<b>Quantity</b>	<b>Description</b>	<b>FTI Part Number</b>
1	Valve, Cartridge Trigger (See Figure 6.1-1, Piece Number 1)	1187-622
1	Seal, LB Handle (See Table 6.3-1, Piece Number 6)	2040-001
2	Ring, Backup MS28782-9	1046-028
1	A-111-90-BUNA	1046-038
2	AN6227-9	1046-027
1	MS-28782-32	1046-024
1	CP-329	1046-029
1	Scraper (R 2072)	1046-037
1	MS28775-214 O-Ring	1046-059
1	MS28775-224 O-Ring	1046-058
1	AN62278-19	1046-025
1	MS-28782-19	1046-026
1	AN6227B-32	1046-023
1	MS228775-147	1046-035
2	AN6227-5	1046-036

### 6.3 PREVIOUS TRIGGER ASSEMBLY

The previous trigger design (serial number less than 0555) can be easily replaced with the improved trigger assembly detailed at the beginning of Section 6.0. Table 6.3-1 is a parts list for the old-style trigger assembly.

**Table 6.3-1  
Parts List for Previous Trigger Assembly**

Quantity	Piece Number	Description	FTI Part Number
1	1	Trigger, LB Handle	2042-001
1	2	Spring, LB Handle	1005-003
1	3	Retainer, LB Handle	2043-001
1	4	Ball, .250 Diameter, stl.	1045-025
1	5	Pin, 1/8 x 3/4 stdl. Spring	1045-026
1	6	Seal, LB Handle	2040-001
1	7	Sleeve, LB Handle	2044-001

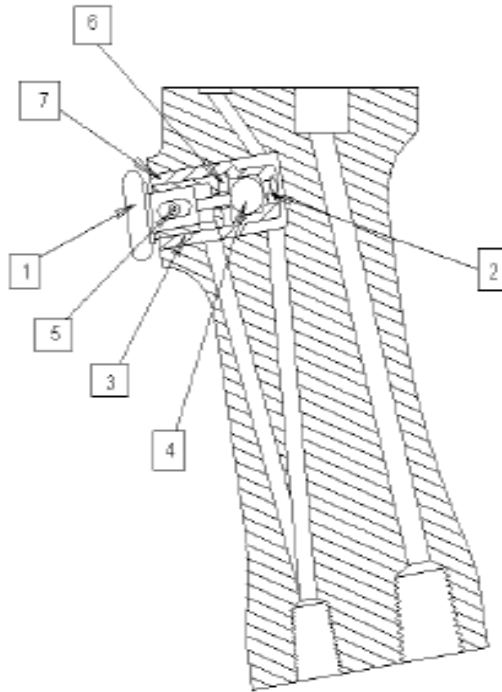

**Figure 6.3-1  
Diagram of Previous Trigger Assembly**

6.4 BIG BRUTE PARTS LIST

Table 6.4-1  
Big Brute Parts List

Quantity												Part No./ Dash No.	Piece No.	Description	Reference Information	
--	--	--	--	--	--	--	--	--	--	--	--	2318-001	-	Assembly, BB-RR Puller with BB-CA-20	BB-RR	
--	--	--	--	--	--	--	--	--	--	--	--	2318-002	-	Assembly, BB-30 Puller with BB-CA-20	BB-30	
--	--	--	--	--	--	--	--	--	--	--	--	2318-003	-	Assembly, BB-70 Puller with BB-CA-20	BB-70	
--	--	--	--	--	--	--	--	--	--	--	--	2318-004	-	Assembly, BB-30 Puller with Threaded Adapters	BB-30A	
--	--	--	--	--	--	--	--	--	--	--	--	2318-005	-	Assembly, BB-70 Puller with Threaded Adapters	BB-70A	
--	--	--	--	--	--	--	--	--	--	--	--	2318-006	-	Assembly, BB-30 Puller with BB-CA-16	BB-30B	
--	--	--	--	--	--	--	--	--	--	--	--	2318-007	-	Assembly, BB-70 Puller with BB-CA-16	BB-70B	
--	--	--	--	--	--	--	--	--	--	--	--	2318-008	-	Assembly, BB-30 Puller with 7/8 - 14 Piston Thread	BB-30C	
--	--	--	--	--	--	--	--	--	--	--	--	2318-009	-	Assembly, BB-RT Puller	BB-RT	
--	--	--	--	--	--	--	--	--	--	--	--	2318-010	-	Assembly, BB-30 with BB-CA-20/25' Hose	BB-30-H25	
--	--	--	--	--	--	--	--	--	--	--	--	2318-011	-	Assembly, BB-30 with Threaded Adapters/25' Hose	BB-30A-H25	
--	--	--	--	--	--	--	--	--	--	--	--	2318-012	-	Assembly, BB-30-737 Puller with BB-CA-20	BB-30-737	
--	--	--	--	--	--	--	--	--	--	--	--	2318-013	-	Assembly, BB-100 Puller with Threaded Adapters	BB-100	
1	1	1	1	1	1	1	1	1	1	1	1	2192-001	2	Sleeve	BB-D2	
--	--	--	--	1	--	--	--	--	--	--	--	2184-001	3	Cylinder	BB-RR-D3	
1	1	1	1	1	--	1	--	1	--	1	--	2184-003	3	Cylinder	BB-30-D3	
--	--	--	--	--	1	--	1	--	1	--	--	2184-004	3	Cylinder	BB-70-D3	
1	--	--	--	--	--	--	--	--	--	--	--	2184-005	3	Cylinder	BB-100-D3	
--	--	--	--	--	1	--	--	--	--	--	--	2105-001	4	Assembly, Piston	BB-RR-D4	
1	1	1	1	1	--	1	--	1	--	1	--	2105-002	4	Assembly, Piston	BB-30-D4	
--	--	--	--	--	1	--	1	--	1	--	--	2105-003	4	Assembly, Piston	BB-70-D4	
--	--	--	--	--	1	--	--	--	--	--	--	2105-005	4	Assembly, Piston	-----	
1	--	--	--	--	--	--	--	--	--	--	--	2105-006	4	Assembly, Piston	BB-100-D4	
--	--	--	--	--	--	--	--	--	--	--	--	2187-002	5	Barrel	BB-RR-D5	
1	1	1	1	1	--	1	--	1	--	1	--	2187-003	5	Barrel	BB-30-D5	
--	--	--	--	--	1	--	1	--	1	--	--	2187-004	5	Barrel	BB-70-D5	
1	--	--	--	--	--	--	--	--	--	--	--	2187-005	5	Barrel	BB-100-D5	
--	--	--	--	1	--	--	--	--	--	--	--	2952-001	5	Barrel	RTB-11	
2	2	2	2	2	2	2	2	2	2	2	2	1035-002	6	Screw, Socket Head Cap	1/4-20UNC-2A X 3/8 LONG	
1	1	1	1	1	1	1	1	1	1	1	1	2007-007	7	Washer	BB-D7	
1	1	1	1	1	1	1	1	1	1	1	1	2127-001	8	Housing	BB-D8	
1	1	1	1	1	1	1	1	1	1	1	1	2201-001	9	Locknut	BB-D16	
--	--	--	--	--	1	--	--	--	--	--	--	2201-002	9	Locknut	-----	
1	1	1	1	1	1	1	1	1	1	1	1	2323-001	10	Sleeve, End Cap	-----	
1	1	1	1	1	1	1	1	1	1	1	1	2324-001	11	Adapter, Air	-----	
--	--	--	--	1	--	--	--	--	--	--	--	2328-001	12	Tube, Air	BB-RR-D19	
1	1	1	1	1	--	1	--	1	--	1	--	2328-002	12	Tube, Air	BB-30-D19	
--	--	--	--	--	1	--	1	--	1	--	--	2328-003	12	Tube, Air	BB-70-D19	
1	--	--	--	--	--	--	--	--	--	--	--	2328-004	12	Tube, Air	BB-100-D19	
--	--	--	--	--	--	--	--	--	--	--	--	2074-001	13	Nosecap	-----	
--	1	--	--	--	--	--	--	--	--	--	--	3003-003	13	Nosecap	-----	
3	3	3	3	3	3	3	3	3	3	3	3	2120-005	14	Lockring	BB-D27	
1	1	--	--	1	--	1	1	1	1	1	1	2107-001	15	Assembly, Hydraulic Hose	IWHH-10	
--	--	--	--	--	1	--	--	--	--	--	--	2107-002	15	Assembly, Hydraulic Hose	IWHH-20	
--	--	1	1	--	--	--	--	--	--	--	--	2107-008	15	Assembly, Hydraulic Hose	IWHH-25	
1	1	1	1	1	1	1	1	1	1	1	1	5211-003	16	Handle, Sub-Assembly	BB-H-1-SA	
--	1	--	1	--	1	--	--	--	1	1	1	2313-002	17	Assembly, BB Chuck	BB-CA-20	
--	--	--	--	--	1	1	--	--	--	--	--	2313-001	17	Assembly, BB Chuck	BB-CA-16	
1	--	1	--	--	--	--	1	1	--	--	--	2526-001	17	Adapter, 7/8-14UNF-2A Threaded	BB-A-D35	
1	1	1	1	1	1	1	1	1	1	1	1	1046-035	18	O'Ring	MS28775-147 (16650)	
1	1	1	1	1	1	1	1	1	1	1	1	1035-013	19	Screw, Socket Head Cap	1/4-20UNC-2A X 2-1/2 LONG	
2	2	2	2	2	2	2	2	2	2	2	2	1046-036	20	O'Ring	AN6227B-5 (16650)	
1	1	1	1	1	1	1	1	1	1	1	1	1046-037	21	Scraper	R2072 (16650)	
1	1	1	1	1	1	1	1	1	1	1	1	1046-025	22	O'Ring	AN6227B-19 (16650)	
1	1	1	1	1	1	1	1	1	1	1	1	1046-026	23	Ring, Backup	MS28782-19 (16650)	
1	1	1	1	1	1	1	1	1	1	1	1	1046-023	24	O'Ring	AN6227B-32 (16650)	
1	1	1	1	1	1	1	1	1	1	1	1	1046-024	25	Ring, Backup	MS28782-32 (16650)	
1	1	1	1	1	1	1	1	1	1	1	1	1046-038	26	O'Ring	A-111-90 BUNA (16650)	
2	2	2	2	2	2	2	2	2	2	2	2	1045-027	27	Screw, Set	10-32UNF 2A X 1/4 LONG	
1	1	1	1	1	1	1	1	1	1	1	1	2197-001	29	Cap, End	BB-D46	
--	--	--	--	--	--	--	--	--	--	--	--	5442-001	29	Cap, End	-----	
1	1	1	1	1	1	1	1	1	1	1	1	1045-015	30	Wrench, Spanner	0-474 (03100)	
1	1	1	1	1	1	1	1	1	1	1	1	1009-185	31	Label	"WARNING" LABEL	
1	1	1	1	1	1	1	1	1	1	1	1	1009-094	32	Label	"FTI" LABEL	
1	1	1	1	1	1	1	1	1	1	1	1	1009-184	33	Label	"DO NOT STRIKE" LABEL	
2	2	2	2	2	2	2	2	2	2	2	2	1009-188	34	Label	"BIG BRUTE" LABEL	
1	1	--	--	1	--	1	1	1	1	1	1	2106-001	35	Assembly, Air Hose (Male)	IWAH-10	
--	--	--	--	--	1	--	--	--	--	--	--	2106-003	35	Assembly, Air Hose (Male)	IWAH-20	
--	--	1	1	--	--	--	--	--	--	--	--	2106-015	35	Assembly, Air Hose (Male)	IWAH-25	
1	1	--	--	1	--	1	1	1	1	1	1	2106-002	36	Assembly, Air Hose (Female)	IWAH-10	
--	--	--	--	--	1	--	--	--	--	--	--	2106-004	36	Assembly, Air Hose (Female)	IWAH-20	
--	--	1	1	--	--	--	--	--	--	--	--	2106-016	36	Assembly, Air Hose (Female)	IWAH-25	
4	4	4	4	4	4	4	4	4	4	4	4	2638-001	37	Tube, Heat Shrink	3" LONG	√
1	--	1	--	--	--	--	1	1	--	--	--	2526-002	-	Adapter, 1-14UNS-2A, Threaded	BB-8-D35	√
1	1	1	1	1	1	1	1	1	1	1	1	1045-116	-	Wrench, Open End	(ARMSTRONG 28-056)	√
1	--	1	--	--	--	--	1	1	--	--	--	2526-003	-	Adapter, 1-14UNS-2A, Threaded	BB-C-D35	√
--	--	--	--	1	--	--	--	--	--	--	--	1045-188	-	Wrench, Open End	2-1/2" 28-080	
1	1	1	1	1	1	1	1	1	1	1	1	1166-001	38	Label "CE"	-----	
1	1	1	1	1	1	1	1	1	1	1	1	1187-105	39	Label "Hearing Protection"	-----	
1	1	1	1	1	1	1	1	1	1	1	1	1187-106	40	Label "Eye Protection"	-----	
1	1	1	1	1	1	1	1	1	1	1	1	1187-107	41	Label "Read Manual"	-----	
--	--	--	--	--	--	--	--	--	--	--	--	1187-770	-	Enerpac CT-604 Pressure Relief Tool	NOT INCLUDED	√

√ Items flagged thus are included as part of assembly, but are not installed into puller.

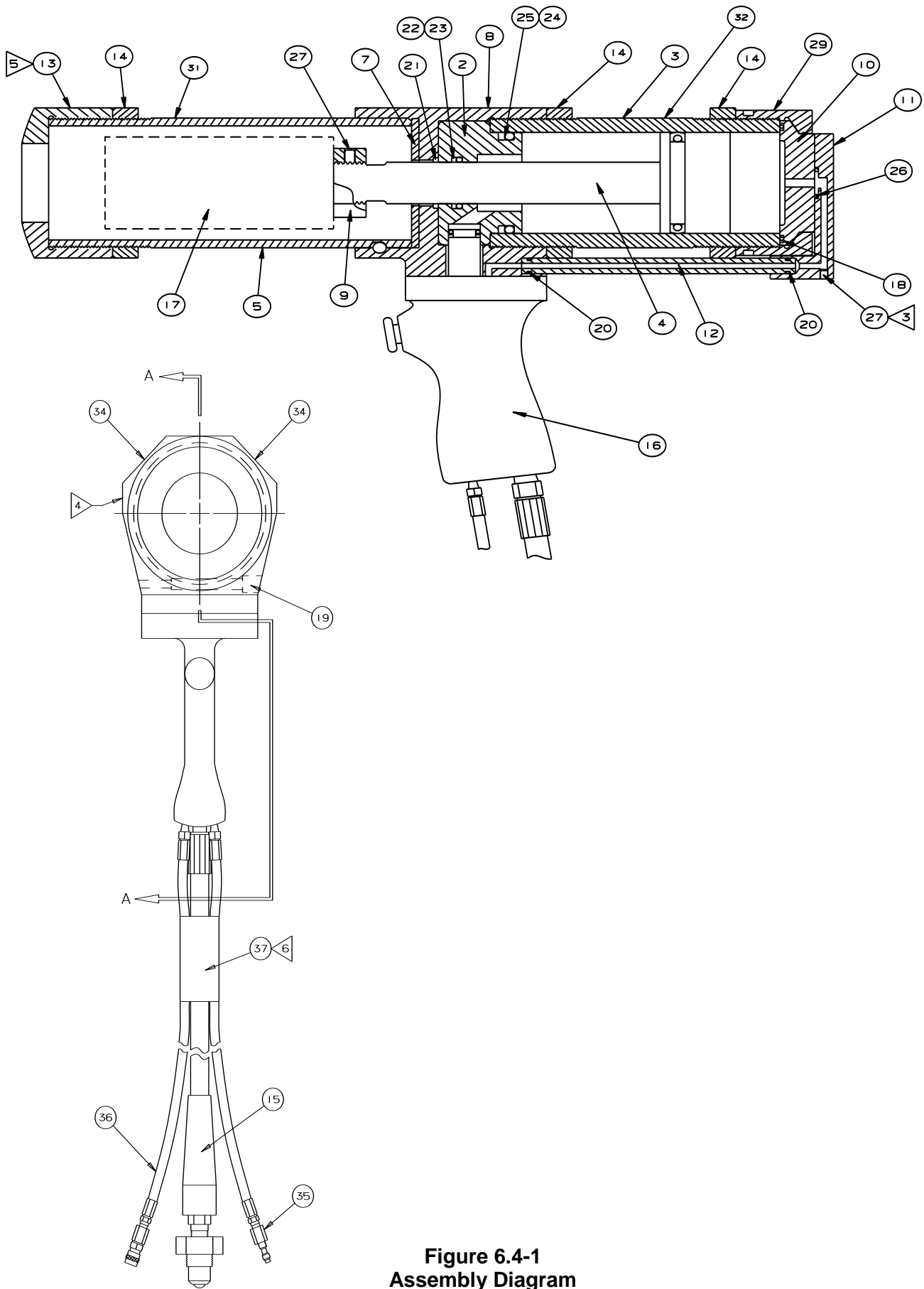

**Figure 6.4-1  
Assembly Diagram**





FATIGUE TECHNOLOGY  
401 Andover Park East  
Seattle, Washington 98188-7605  
USA

## **E.C. DECLARATION OF CONFORMITY**

Manufacturer: Fatigue Technology  
401 Andover Park East  
Seattle, WA 98188-7605

Telephone: (206) 246-2010  
Fax: (206) 244-9886

Responsible Person in E.C.: Keith Huxley  
FT-Ltd.  
Rosevear  
Level Road  
Hawarden, Deeside CH5 3JR  
United Kingdom

Telephone: 44 1244 538730  
Fax: 44 1244 534423

The undersigned declares that the machinery described:

Type:

Serial Number:

conforms to the following directives:

Council Directive 2006/42/EC (the Machinery Directive)  
EN 792-1 Hand-Held Non-Electric Power Tools – Part 1  
EN 982 Safety Requirements for Fluid Power Systems and Their Components –  
Hydraulics  
EN 983 Safety Requirements for Fluid Power Systems and Their Components --  
Pneumatics

and complies with the relevant health and safety requirements.

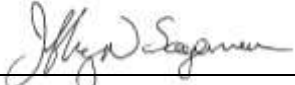
  
\_\_\_\_\_  
Jeff Sageman  
*Logistics Manager*

January 17, 2014  
\_\_\_\_\_  
Date

This page intentionally left blank for two-sided printing.