FTI OPERATIONS, MAINTENANCE, AND REPAIR MANUAL

**Jumbo Brute (JB-60 and JB-30 Series)
Cylinder Puller Unit**

**FTI Part #2720-062
Log #02640
Revision D**

January 17, 2014



JB-60 Series

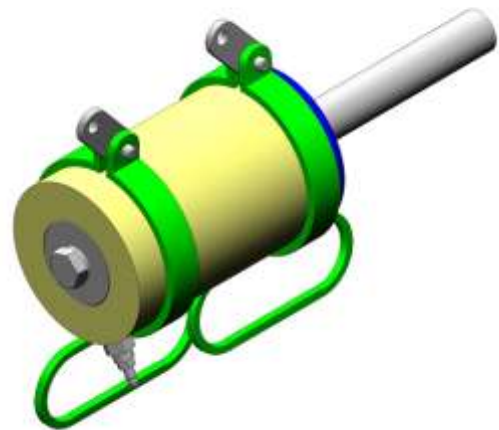

JB-30 Series



Fatigue Technology (FTI) is the supplier of Split Sleeve Cold Expansion™ (Cx™) systems to the aerospace industry worldwide. These proprietary systems and associated tooling may be covered by patents or agreements owned by, or exclusively licensed to Fatigue Technology. Use of tooling procured from other than a licensed source may constitute patent infringement.

The detailed tooling information in this manual was compiled and written by FTI. The tooling was designed specifically for use with FTI's Cx Systems. FTI cannot be held responsible for damage or injury as a result of operating this equipment if it is used for other than the process intended, with any other tooling not provided by FTI, or not used in accordance with the instructions contained in this manual. To avoid personal injury, please observe all safety precautions and instructions. FTI reserves the right to change specifications or configurations of equipment detailed in this manual as part of our ongoing technical and product improvement programs. If you have any questions about the use or serviceability of this equipment, please contact our Sales Department.

FTI's systems and processes are the subject matter of one or more of the following patents: 4,809,420; 4,885,829; 4,934,170; 5,083,363; 5,096,349; 5,103,548; 5,127,254; 5,218,854; 5,245,743; 5,305,627; 5,341,559; 5,380,136; 5,405,228; 5,433,100; 5,468,104; 6,077,010; 6,183,180; 6,487,767; 6,792,657; 5,129,253; 513,898; 692015124; 581,385; 69310828; 468,598; 69105390; 643,231; 69414946; 696,686; 785,366; and other patents pending. These systems and processes are tooling critical and must be performed in accordance with FTI's specifications or controlling documents. To ensure proper results from FTI's cold expansion systems and to be licensed to use FTI's patented processes, it is essential that FTI's complete integrated system of tooling be purchased and utilized. The use of tooling purchased from other than a licensed supplier could jeopardize fatigue life enhancement and may constitute patent infringement.

Fatigue Technology (FTI) has provided innovative solutions to fatigue problems in metal structures since 1969. Complete systems of tooling are used worldwide to enhance the fatigue life of holes in airframes, turbine engines, and other critical structures.

The FTI staff of professionals provides a full range of support services including:

- Application engineering
- Detailed project planning, implementation and management
- On-site assistance, including training and tool room setup

The Sales Department is always available to assist with special fatigue enhancement requirements. Please contact FTI with questions at any time.

TABLE OF CONTENTS

SECTION	DESCRIPTION	PAGE
Section 1.0	Introduction.....	1
1.1	About the Jumbo Brute Cylinder Puller Unit.....	1
1.2	General Description.....	1
1.3	General Specifications.....	2
Section 2.0	Safety	5
Section 3.0	Puller Unit Operating Instructions.....	7
3.1	Puller Unit Setup Procedure and Operation	7
3.2	Activation of Puller Unit.....	8
3.3	Tooling Setup	8
3.4	PowerPak Pressure Adjustment.....	9
Section 4.0	Puller Unit Maintenance	10
4.1	General Cleaning	10
4.2	Lubrication	10
4.3	Inspection	10
4.4	Disassembly.....	10
Section 5.0	Troubleshooting.....	11
Section 6.0	Illustrated Parts Breakdown.....	15
6.1	Jumbo Brute Series Puller Unit Diagram.....	15
6.2	Jumbo Brute Series Puller Unit Assembly Parts List.....	16
6.3	Jumbo Brute Series Remote Trigger Assembly; Parts List.....	17

FIGURES

Figure 1.3-1	Jumbo Brute Series Parts.....	2
Figure 1.3-2	JB-60 Series Dimensions	3
Figure 1.3-3	JB-30 Series Dimensions	4
Figure 2.0-1	Safety Stickers	5
Figure 2.0-2	Location of Air Disconnect (FT-200D Model)	5
Figure 3.1-1	Puller and PowerPak Hose Connections.....	7
Figure 3.1-2	Remote Trigger Hose Connections.....	8
Figure 3.2-1	Jaw on Puller Unit	8
Figure 3.2-2	Mandrel on Puller Unit	9
Figure 3.3-1	PowerPak Pressure Adjustment	9
Figure 5.0-1	PowerPak Hose Connections	11
Figure 5.0-2	Tightened Hose Connections	12
Figure 5.0-3	Enerpac CT-604 Pressure Relief Tool.....	12
Figure 5.0-4	Trigger Response Valve.....	13
Figure 5.0-5	PowerPak Pressure Adjustment.....	14

TABLE OF CONTENTS (CONTINUED)

SECTION	DESCRIPTION	PAGE
---------	-------------	------

Figures (Continued)

Figure 6.1-1	Jumbo Brute Series Diagram	15
Figure 6.3.1-1	Diagram of Remote Trigger Assembly	17
Figure 6.3.2-1	Diagram of Original Trigger Assembly	18
	E.C. Declaration of Conformity	19

TABLES

Table 1.3-1	JB-60 Series Specifications	3
Table 1.3-2	JB-30 Series Specifications	4
Table 6.2-1	Jumbo Brute Series Parts List	16
Table 6.3.1-1	Parts List for Cartridge Trigger Assembly Kit	17
Table 6.3.2-1	Parts List for Original Trigger Assembly	18

SECTION 1.0: INTRODUCTION

This instruction manual contains information on the operation and maintenance of the Jumbo Brute Cylinder Puller Unit. To obtain optimum performance and many years of trouble free service, operate the puller unit properly and carefully follow maintenance procedures.

Read this manual before operating the Puller Unit and retain it for future reference. If requested, FTI will provide this manual in the language of the end-user.

1.1 ABOUT THE JUMBO BRUTE CYLINDER PULLER UNIT

The Jumbo Brute series Puller Unit is a powerful, heavy-duty tool specifically designed for use with all Fatigue Technology (FTI) Cold Expansion (CX™) processes. The Jumbo Brute Puller Unit is designed to pull a mandrel through a hole with the pre-lubricated stainless steel split sleeves used in this process, or pre-lubricated bushing used in the ForceMate® (FmCX™) process.

The Jumbo Brute Puller Unit has a maximum pull force of 60,000 pounds (266.89kN) at 10,000 psi (68.95MPa) pump pressure. The Jumbo Brute is available for cold expanding holes over 1-1/2 inch (38mm) in diameter in aluminum, steel, and titanium. Please contact FTI technical support staff for application assistance.

The JB-60 will accommodate tooling for a stack-up of approximately five inches (125mm).
The JB-30 will accommodate tooling for a stack-up of approximately two inches (50.8mm).

The Jumbo Brute has a fail-safe air control system that causes the puller retraction cycle to be interrupted whenever the operator releases finger pressure on the trigger or in the event of air or hydraulic hose failure. The Puller Unit operates in conjunction with FTI's FT-200 PowerPak air-hydraulic power units. (The portable FT-20 PowerPak is not recommended.)

1.2 GENERAL DESCRIPTION

Hydraulic Fluid Requirements.....	U.S. MIL-H-5606
Operating Hydraulic Pressure.....	10,000 psi (68.95MPa)
Pull Force Capacity	60,000 pounds (266.89kN)
PowerPak Air Line Requirements	3/8 inch to 1/2 inch (9.5 to 12.7mm) inside diameter
PowerPak Air Flow Requirements	90 to 120 psi (0.62 to 0.82MPa), 50 cfm (1.42m ³ /min)
Actuation	Pneumatic
Operation	Hydraulic
Compatible PowerPak	FT-200
Fail-Safe.....	Air logic safety circuit halts mandrel retraction when trigger is released

Weight:* (see note on next page)

JB-60	64 lbs. (29 kg)
JB-60A.....	66 lbs. (30 kg)
JB-60B.....	72 lbs. (32.6 kg)
JB-60C.....	64 lbs. (29 kg)
JB-60D.....	70 lbs. (31.8 kg)
JB-60E.....	69 lbs. (31.3 kg)
JB-30	50 lbs. (22.7 kg)
JB-30A.....	48 lbs. (21.8 kg)
JB-30-968	48 lbs. (21.8 kg)

*A user supplied suspension system might be required at the end use site. The requirement for a suspension system is based on the end user's workplace lifting and weight standards. A risk analysis for the suspension is necessary to maintain compliance to end user's standards or directives. All risks involved with the suspension of the Jumbo Brute series Puller Units are the responsibility of the end user. User instructions and training regarding the suspension system are the responsibility of the end user.

1.3 GENERAL SPECIFICATIONS

The Jumbo Brute series Puller Unit is designed for applications where the capacity of the Big Brute Puller Unit is exceeded.

Tooling Selection: The mandrels and nose caps used with the Jumbo Brute Puller Units are designed to the specific needs of the customer and application requirements. Please contact FTI technical support staff for application assistance, if needed.

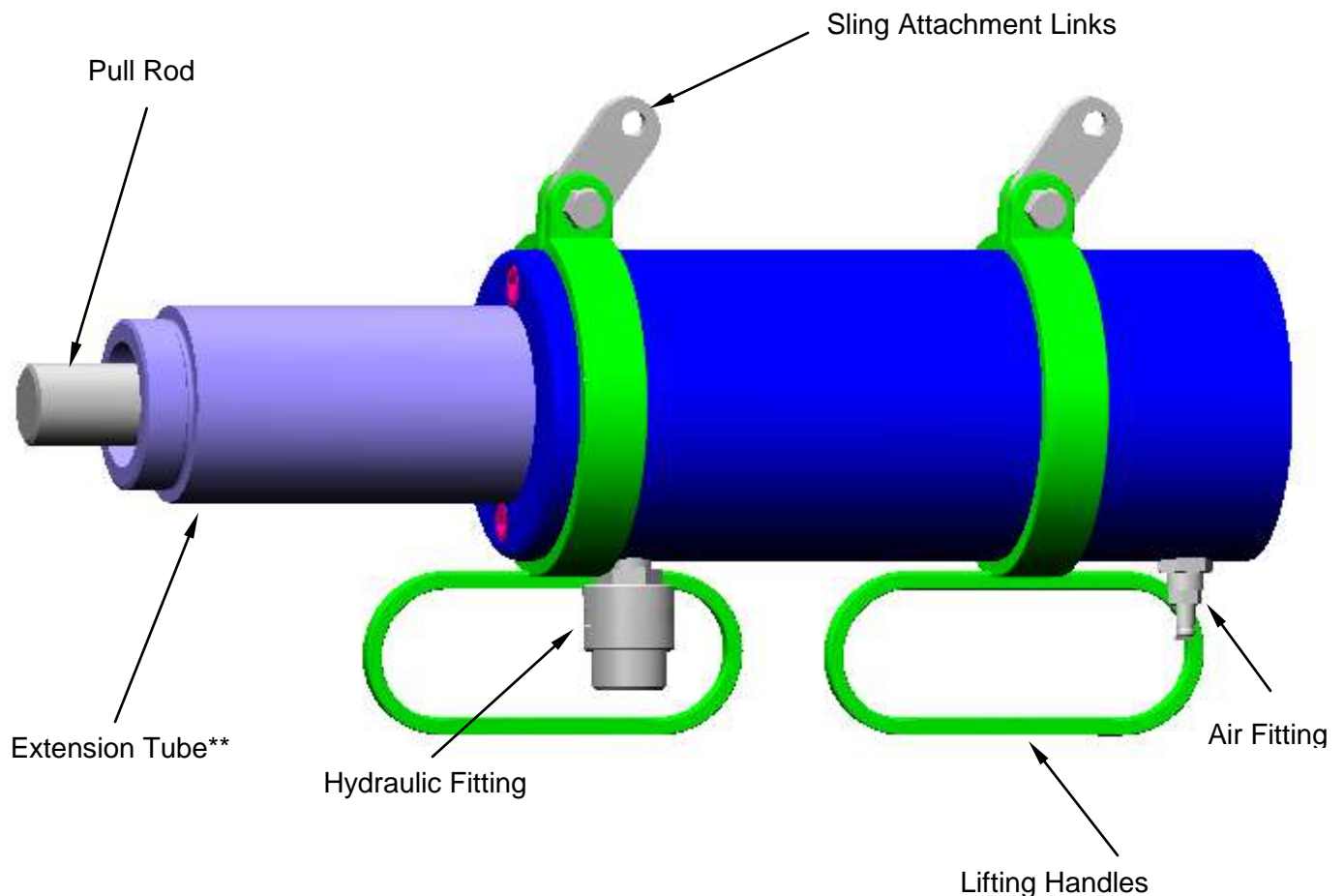

Figure 1.3-1
Jumbo Brute Series Parts

** Extension Tube not used on JB-30 series Puller Units

**Table 1.3-1
JB-60 Series Specifications**

Model Number	Maximum Material Stackup inch (mm)	Length inch (mm)	Stroke inch (mm)	Weight ¹ lb (kg)	Shipping Weight lb (kg)
JB-60	≈ 5 (125)	19.99 (508)	6.0 (152)	64 (29)	108 (49)
JB-60A	≈ 5 (125)	19.99 (508)	6.0 (152)	66 (30)	110 (50)

Note 1: Puller only, does not include hoses or tooling.

Note 2: Dimensional information for other JB-60x Model Numbers was not included at the time of printing. Please contact FTI for additional information on those units.

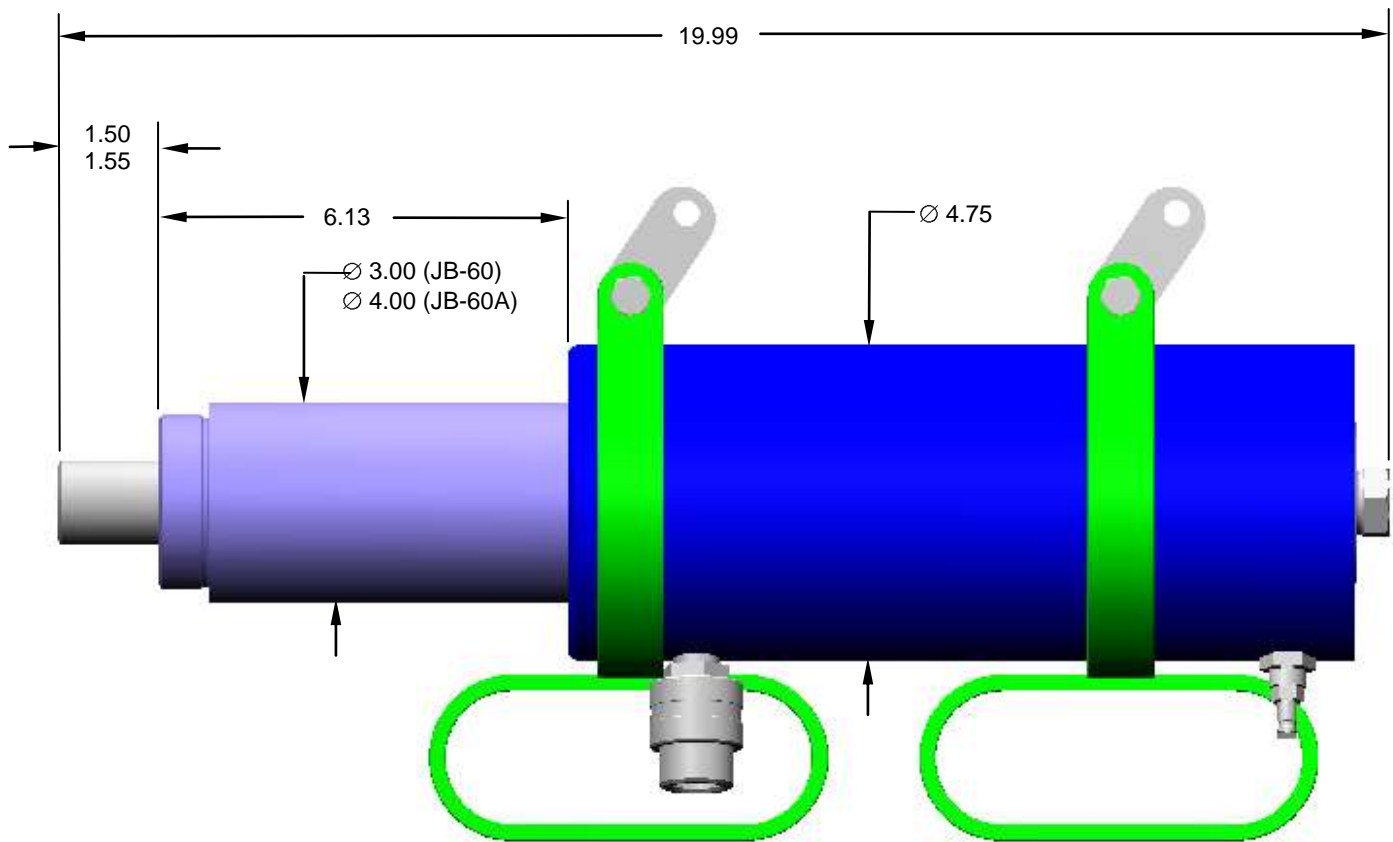
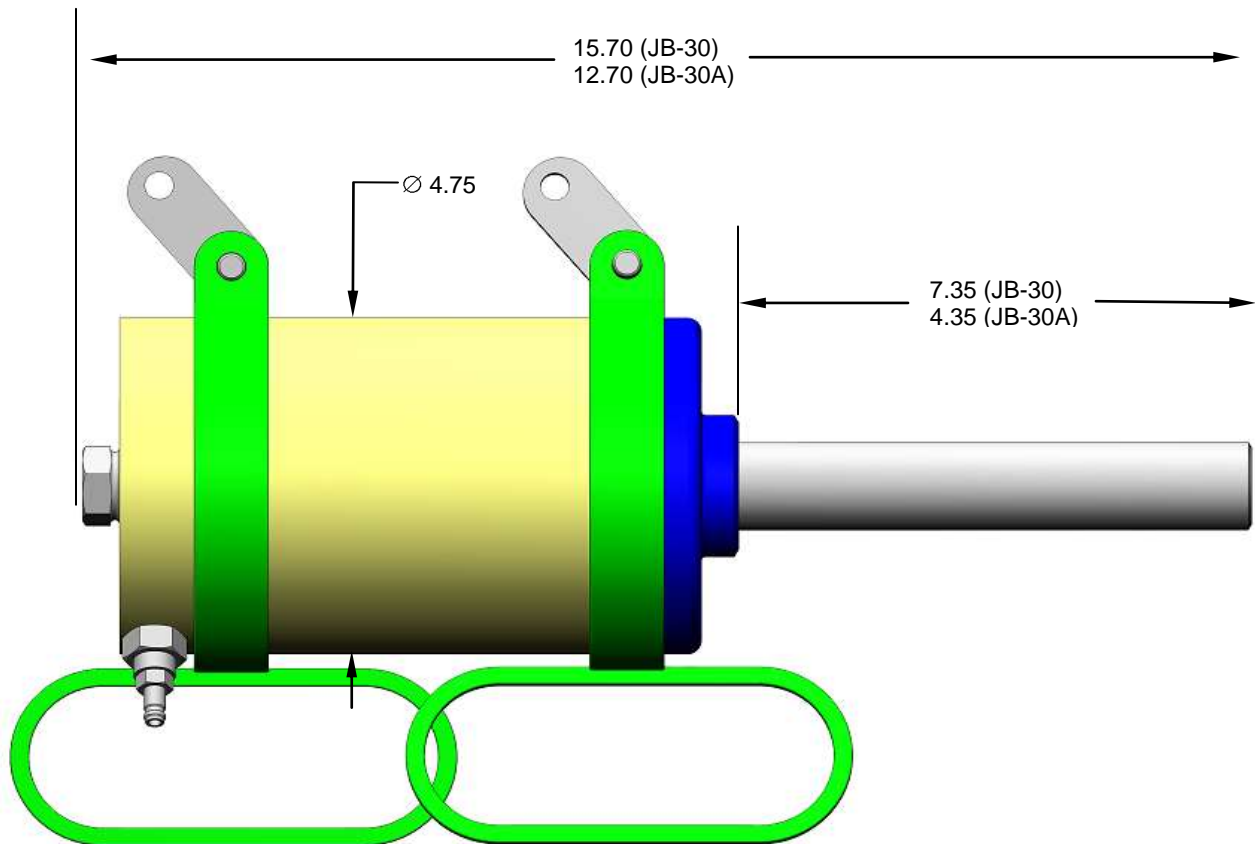

**Figure 1.3-2
JB-60 Series Dimensions**

**Table 1.3-2
JB-30 Series Specifications**

Model Number	Maximum Material Stackup inch (mm)	Length inch (mm)	Stroke inch (mm)	Weight ¹ lb (kg)	Shipping Weight -- approximate lb (kg)
JB-30	2 (50.8)	15.70 (398.78)	3 (76.2)	50 (22.7)	90 (40.8)
JB-30A	2 (50.8)	12.70 (322.58)	3 (76.2)	48 (21.8)	88 (39.9)

Note 1: Puller only, does not include hoses or tooling.



**Figure 1.3-3
JB-30 Series Dimensions**

SECTION 2.0: SAFETY

When used in accordance with these instructions, the Puller Unit is safe and easy to use. All general safety precautions associated with hydraulic and pneumatically operated power tools should be observed. Many of these are noted in this section.

The Jumbo Brute Puller Unit is not intended for hand-held operation. The strap handles are provided to carry or to maneuver the puller into position. The sling attachment links are provided for ease of attachment to the operator's hoist apparatus. A sling made from chain, cable or strap with minimum load capacity certification is highly recommended. **DO NOT** use rope or other materials not intended for material handling.

Ultimately, operators are responsible for their own safety; however, the following general safety precautions should be observed. Refer to Figure 2.0-1.

CAUTION: The weight of this unit may require a suspension system per the end-user's workplace lifting standards.

Read manual before using

Always wear eye protection

Always wear ear protection



**Figure 2.0-1
Safety Stickers**

1. Wear eye and ear protection when operating the puller unit.
2. Disconnect the air supply when:
 - Maintenance is performed
 - Repair work is performed
 - Hydraulic hose is disconnected
 - PowerPak is not in use
3. In the event of a ruptured or leaking hydraulic hose, **IMMEDIATELY RELEASE THE TRIGGER AND DISCONNECT THE AIR LINE** at the air coupler from the PowerPak (see Figure 2.0-2). **Never use your hands** to grasp a leaking hose under pressure. The force of escaping hydraulic fluid could cause serious injury. If hydraulic oil should penetrate the skin, medical attention must be sought immediately.
4. Keep hands away from nosecap assembly while activating the Puller Unit.



**Figure 2.0-2
Location of Air Disconnect
(FT-200D Model)**

5. Release puller unit trigger when mandrel clears the workpiece, or becomes stuck.
6. Before operating the pump, tighten all hose connections using the proper tools. Do not overtighten the connections. Connections need only be tightened securely and leak-free. Overtightening may cause premature thread failure or high-pressure fittings to split at pressures lower than their rated capacities.
7. Operators must read this manual in its entirety before using the puller unit. Eye and ear protection must be worn while operating the puller unit. Three safety stickers on the puller unit act as a reminder to these instructions. The symbols are defined in Figure 2.0-2 (on the next page).
8. Do not use in potentially explosive atmospheres.

Hydraulic Hose Safety

9. Inspect hydraulic hose for signs of wear (cuts, abrasions, or kinks) to the outer shell materials. Pump clean oil through the entire length. Pressurize the hose and check for leaks at the crimped connectors, between the hose material and the fitting, and between the fitting and the coupler.
10. **DO NOT** attempt to disconnect the hydraulic hose while it is under pressure.
11. **DO NOT** expose hoses to potential hazards such as extreme heat or cold, sharp surfaces, or heavy impact.
12. **DO NOT** allow hoses to kink, twist, curl, or bend so tightly that the oil flow within the hose is blocked or reduced. Periodically inspect the hose and fittings for wear or damage that could cause premature failure of the hose or fittings and possibly result in injury. Damaged hoses must be replaced immediately.
13. **DO NOT** use the hose to move attached equipment.
14. **DO NOT** remove strain reliever from hoses.
15. Hose strain relievers must be placed around hose fittings during use. Hoses with damaged strain relievers must be replaced immediately.
16. Hose material and coupler seals must be compatible with hydraulic fluid that meets the requirements of U.S. MIL-SPEC #5606, ISO 46.
17. Hoses must not come in contact with toxic materials such as creosote-impregnated objects and some paints. Keep couplers and hoses clean and free of paint. Hose deterioration due to chemical degradation may cause the hose to fail under pressure. Damaged hoses must be replaced immediately.
18. Before operating pump, make sure all hose connections are tightened securely. **DO NOT** overtighten.
19. If hoses require replacement contact an FTI Sales Coordinator.

IMPORTANT: FTI completed a risk assessment on this unit at our factory. Any modifications done by a third party or the final user are excluded from that risk assessment. As a result, modifications done by a third party or the final user nullify the CE marking.

<p>CAUTION: Operators must read this manual in its entirety before using any of the Jumbo Brute series Puller Units. Eye and ear protection must be worn during operation.</p>

SECTION 3.0: PULLER UNIT OPERATING INSTRUCTIONS

Become familiar with these instructions before operating the puller.

Check to assure a sufficient working envelope for unobstructed operation. Note that during puller operation the backside of the puller (hex end) will extend up to the maximum stroke limit.

3.1 PULLER UNIT SETUP PROCEDURE AND OPERATION

Refer to Section 6 (Illustrated Parts Breakdown) for parts identification.

1. Inspect all threads and fittings for signs of wear or damage and replace them if necessary.
2. Remove the protection sleeve on the pull rod and inspect the threads.
3. Test shop air to ensure that air is clean, dry, and between 90 and 120 psi (0.62 and 0.82MPa) at 50 cfm (1.42m³/min).
4. Uncoil the air-hydraulic extension hose assembly and inspect all threads, couplings and hoses for damage and degradation. Any damaged component must be replaced immediately.
5. Remove thread protectors from the hydraulic fittings and thread the hydraulic hose fitting from the hose assembly (male) onto the hydraulic fitting of the Puller Unit. Wipe fittings clean prior to connecting. Make sure to thread couplers completely together. There should be positive contact between the coupler and the hose-fitting flange (you should not be able to insert a piece of paper between the coupler and the hose fitting flange—see Section 5, Problem 2 for more information). Failure to completely tighten the coupler will prevent the puller from returning to the forward (start) position. Strain relievers must be placed on hose fittings during operation. If strain relievers are worn or damaged, they must be replaced immediately.
6. Connect the female air quick disconnect onto the male fitting of the puller unit (see Figure 3.1-1).
7. Remove thread protectors from the hydraulic fittings and thread the hydraulic hose fitting from the hose assembly (male) onto the hydraulic fitting of the FTI PowerPak (female). Wipe fittings clean prior to connecting. Make sure to thread couplers completely together. Failure to do so will prevent the puller from returning to the forward (start) position. Strain relievers must be placed on hose fittings during operation. If strain relievers are worn or damaged, they must be replaced immediately.
8. Connect the male air quick disconnect attached to the T-fitting into the female coupler of the FTI PowerPak (see Figure 3.1-1).

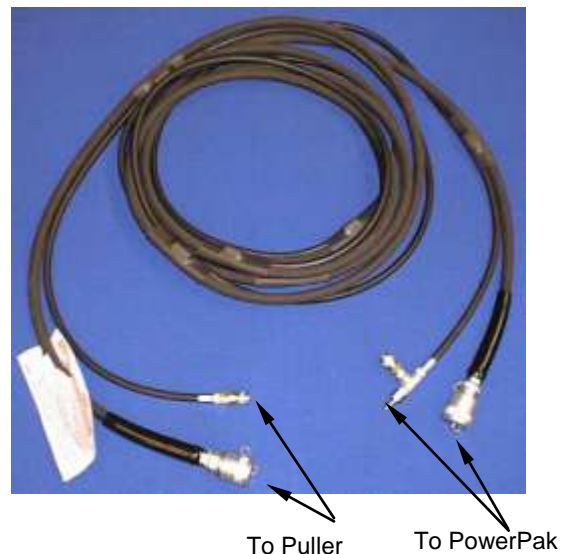

Figure 3.1-1
Puller and PowerPak Hose
Connections

9. Uncoil the trigger assembly and inspect all threads, couplings and hoses for damage and degradation. Any damaged component must be replaced immediately.
10. Connect the female air quick disconnect of the trigger assembly hose to the male fitting of the FTI PowerPak (see Figure 3.1-2).
11. Connect the male air quick disconnect into the female coupler at the T-fitting of the air-hydraulic extension hose assembly (see Figure 3.1-2).
12. Connect the female quick disconnect of a 1/2-inch (12.7mm) ID shop air line onto the male air inlet of the PowerPak (see Figure 3.1-2).

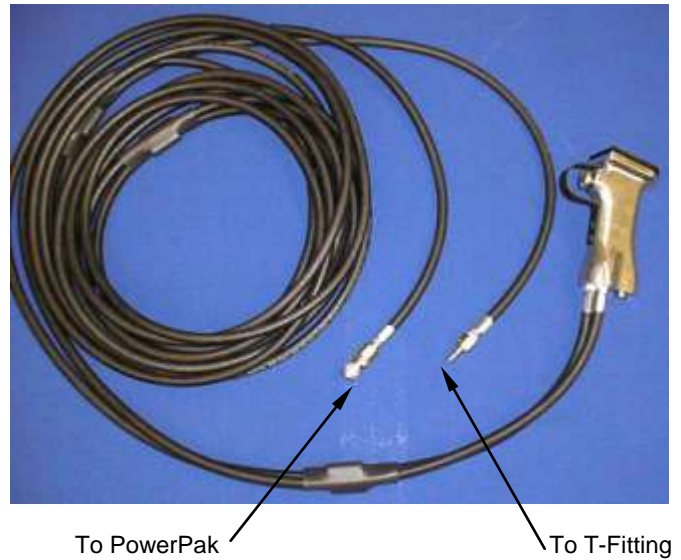

Figure 3.1-2
Remote Trigger Hose
Connections

3.2 *ACTIVATION OF PULLER UNIT*

1. The Puller Unit can be activated only when connected to the FTI PowerPak.
2. Activate Puller Unit by depressing the trigger on the handle. Hydraulic pressure is transmitted through the hose to the cylinder of the puller, which then retracts the hydraulic piston that performs the cold expansion procedure.
3. Releasing the trigger changes pressure at the pilot valve and stops the pull cycle. Air pressure returns the puller to original position.
4. If the Puller Unit fails to operate as detailed above, refer to Section 5 (Troubleshooting).

3.3 *TOOLING SETUP*

1. Thread jaw onto the extension tube of the Jumbo Brute Puller Unit (see Figure 3.3-1). **NOTE:** JB-30 series of Puller Units do not have an extension tube. The jaw threads onto the faceplate. The faceplate is attached directly to the main cylinder with screws.

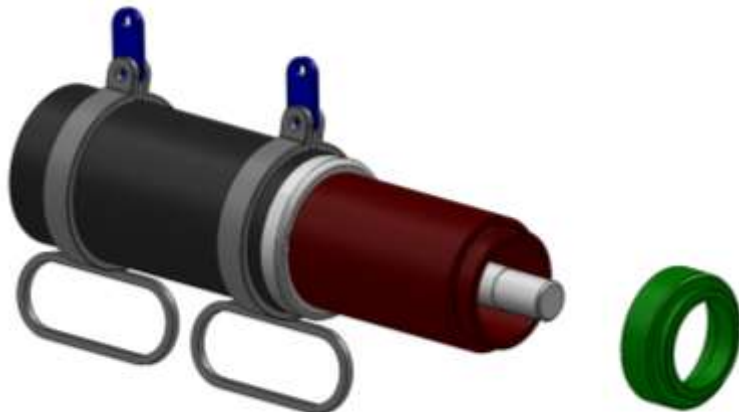

Figure 3.3-1
Jaw on Puller Unit

2. Thread mandrel onto the Pull Rod of the Jumbo Brute Puller Unit (see Figure 3.3-2).

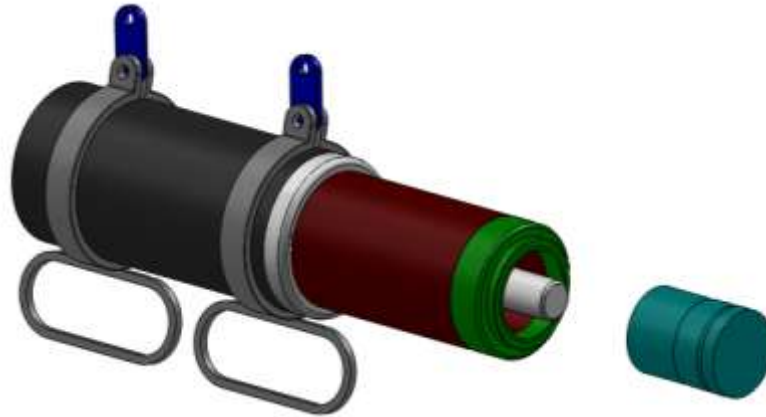

Figure 3.3-2
Mandrel on Puller Unit

3. Cycle the Jumbo Brute Puller Unit without a sleeve or bushing first to ensure the mandrel fully retracts inside the jaw.

3.4 POWERPAK PRESSURE ADJUSTMENT

1. Activate the Puller Unit as described above. Hold the trigger until the PowerPak attains peak pressure and release the trigger two seconds after the peak pressure is reached.
2. If the pressure does not reach 10,000 psi (68.95 MPa), adjust the PowerPak pressure relief valve (see Figure 3.4-1):
 - a. Squeeze the trigger to activate the Puller Unit.
 - b. Loosen the locknut and turn the hydraulic pressure valve clockwise until the pressure reaches 10,000 psi (68.95 MPa).
 - c. Tighten the locknut to secure.

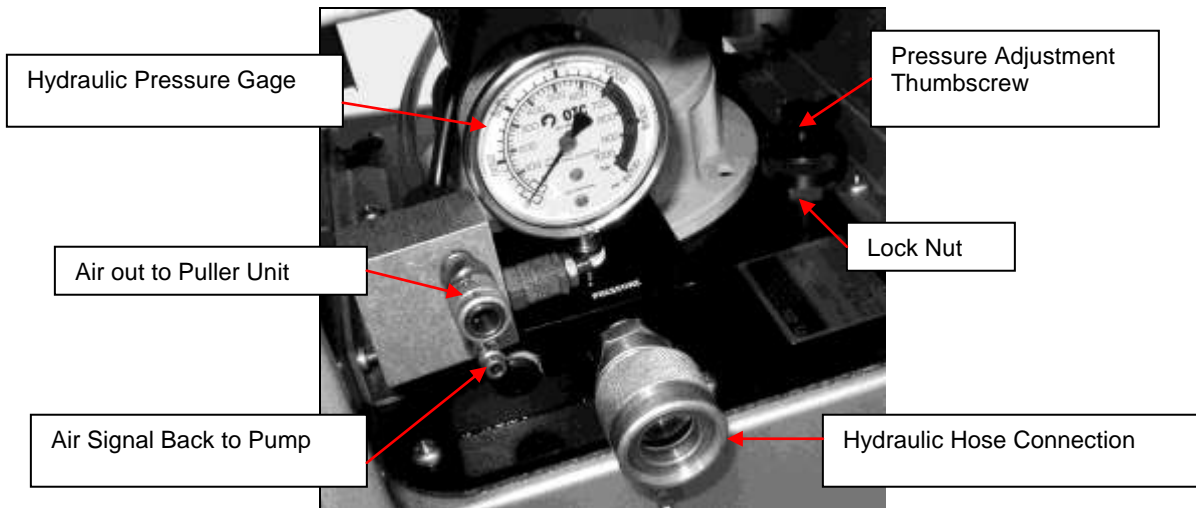

Figure 3.4-1
PowerPak Pressure Adjustment

SECTION 4.0: PULLER UNIT MAINTENANCE

The Puller Unit requires routine checking and periodic preventative maintenance to ensure safe, trouble-free operation. No special maintenance is required. The following maintenance actions are suggested.

CAUTION: Before attempting any maintenance operations on the Puller Unit, disconnect the PowerPak from the air supply or disconnect the puller from the PowerPak or hand pump.

4.1 GENERAL CLEANING

1. Periodically clean the outer surfaces of the Puller Unit and PowerPak.
2. When not in use, ensure thread protectors are re-installed on the hydraulic fittings and the pull rod.
3. Keep all hose connections free of dirt and grime. Doing so will dramatically extend the life of pumps and puller seals.

4.2 LUBRICATION

1. There is no internal lubrication requirement for the Puller Unit.
2. Whenever the puller is to be stored for any length of time, maintain a thin coat of 10-weight oil on the outside of black oxide surfaces.

4.3 INSPECTION

Periodically inspect threaded fittings, hoses, and strain relievers for cracks, leaks or other damage. Repair and replace immediately.

4.4 DISASSEMBLY

The Jumbo Brute Puller Unit is not intended for repair or disassembly in the field. In the event of hydraulic fluid leakage around the seals, the puller should be returned to FTI. Please contact FTI technical support staff for assistance.

SECTION 5.0: TROUBLESHOOTING

This section provides solutions to some basic problems. If you cannot solve your operational problems with the information provided in this section, please contact your nearest FTI representative (see list inside back cover).

PROBLEM	CAUSE	SOLUTION
1. PowerPak will not build full hydraulic pressure.	(a) One or more of the key air or hydraulic lines has not been securely connected.	(a) Check the following hose connections (see Figure 5.0-1): (1) Main air line quick disconnect fitting from shop air system to PowerPak. (2) Hydraulic quick couplings connecting the hoses to the PowerPak manifold and the puller to the hydraulic hoses. (3) Two male/female air line quick disconnect fittings connecting the puller and trigger to the PowerPak manifold.
	(b) Inadequate external pressure.	(b) Adjust external pressure regulator.
	(c) Inadequate air supply.	(c) Check the main air supply has not been interrupted and meets minimum flow requirements (90 psi (0.62MPa), 50 cfm (1.42m ³ /min)).

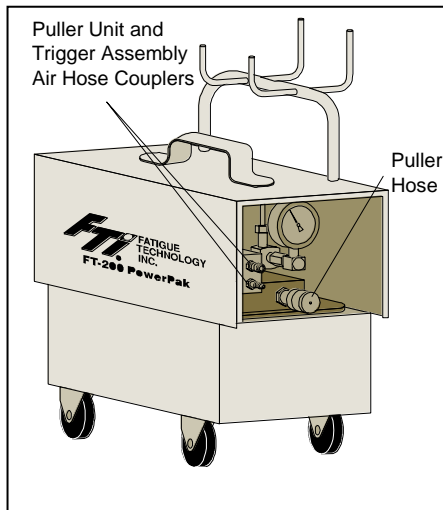

Figure 5.0-1
PowerPak Hose Connections

NOTE: Should difficulties originate in the PowerPak, consult the specific PowerPak Operations, Maintenance and Repair Manual. Remember, always disconnect the PowerPak main air supply before performing any repair or maintenance.

PROBLEM**CAUSE****SOLUTION**

2. Puller retracts on first trigger actuation but will not return to start position

(b) **AND** The hydraulic hose is difficult to bend or coil (indicating unrelieved pressure built up in the hose).

(a) The new Puller Unit requires lubrication through the piston and cylinder.

(b) The hydraulic quick coupler line has not been completely tightened at the PowerPak manifold. There should be no space between the PowerPak couple and the hose fitting flange (see Figure 5.0-2).

(a) Cycle trigger several times to introduce hydraulic fluid into the cylinder.

(b) Once hydraulic pressure has been introduced to the hydraulic hose, the pressure must be relieved before the coupler can be sufficiently tightened.

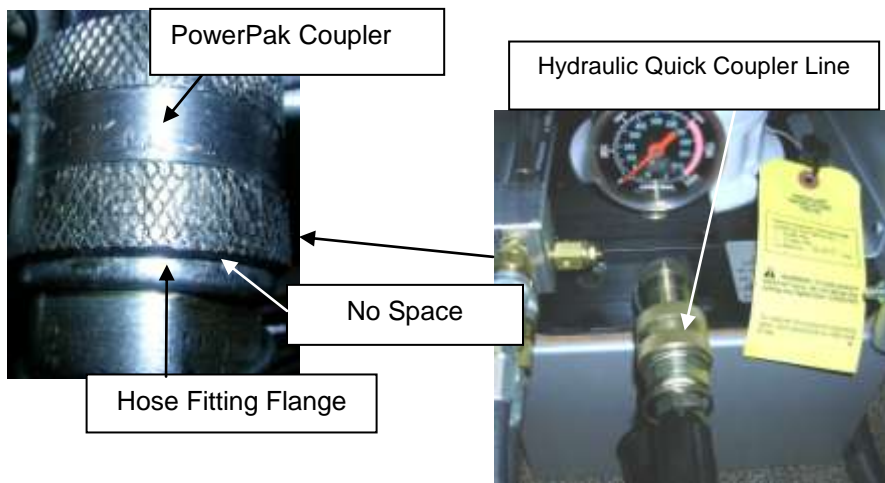

**Figure 5.0-2
Tightened Hose Connections**



**Figure 5.0-3
Enerpac CT-604 Pressure Relief Tool**

Procedure for relieving hydraulic pressure:

- (1) Disconnect main air supply.
- (2) Disconnect coupler from PowerPak.
- (3) Connect Enerpac CT-604 to the coupler and bleed off hydraulic oil to relieve the built-up pressure. Figure 5.0-3 shows the Enerpac CT-604 Pressure Relief Tool.
- (4) Once pressure is relieved, coupler may be tightened and reinstalled onto PowerPak.
- (5) Reattach air lines to get puller to return.
- (6) Check oil level in PowerPak reservoir.

CAUTION: Hydraulic oil under extreme pressure may cause serious injuries if not handled carefully. For technical assistance, please contact FTI's technical support staff.

PROBLEM**CAUSE****SOLUTION**

3. PowerPak will not generate constant pressure (or hiccups).

(a) Trigger response valve requires adjustment.

(a) Adjustment procedure (see Figure 5.0-4):

- (1) Loosen locknut on trigger response valve.
- (2) Using a screwdriver, open screw counterclockwise until PowerPak will not start when puller trigger is depressed.
- (3) Turn screw clockwise until:
 - PowerPak generates constant pressure when puller trigger is depressed, and
 - PowerPak starts instantly when puller trigger is depressed and stops instantly when released.When the puller trigger is depressed, the PowerPak should be run at the pre-set pressure until the trigger is released.

(4) Hold set screw in position and tighten locknut until snug.

Trigger Response Valve

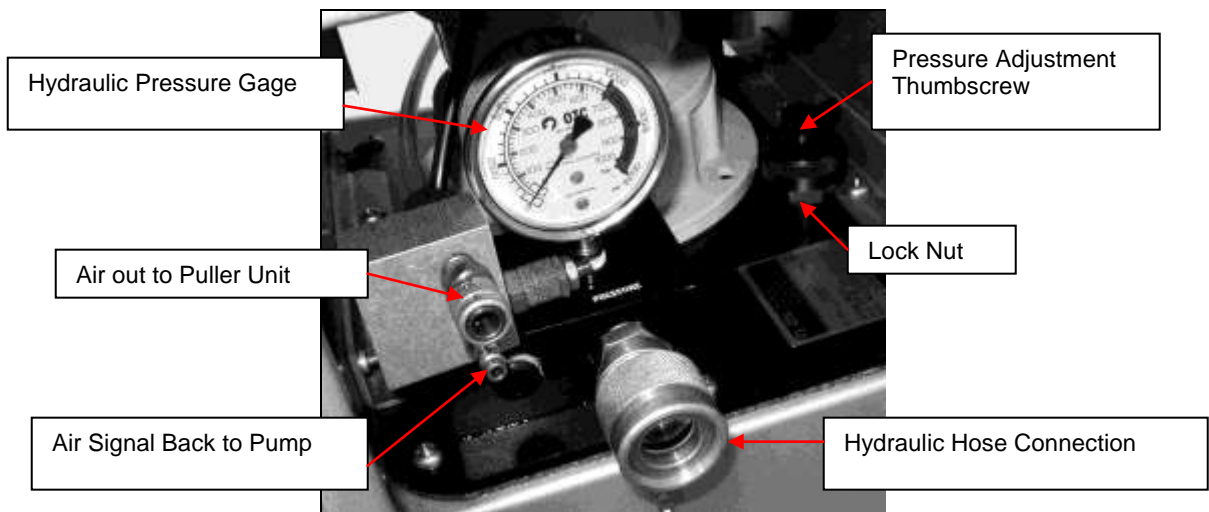

**Figure 5.0-4
Trigger Response Valve**

(b) Inadequate air supply.

(b) Check main air flow for 90 psi (0.62MPa), 0cfm(1.42m³/min).

PROBLEM	CAUSE	SOLUTION
<p>4. PowerPak will not operate or maintain sufficient pressure (10,000 psi (68.95MPa)).</p>	<p>a) Hydraulic pressure requires adjusting.</p> <p>(b) Inadequate air supply.</p>	<p>(a) Adjust PowerPak pressure valve (see Figure 5.0-5):</p> <ol style="list-style-type: none"> (1) Squeeze trigger on puller unit to activate PowerPak. (2) If pressure does not reach 10,000 psi (68.95MPa), loosen lock and turn hydraulic pressure control clockwise until pressure reaches 10,000 psi (68.95MPa). (3) Tighten locknut to secure. <p>(b) Increase pressure or flow of available shop air.</p> <ul style="list-style-type: none"> - If the PowerPak will not generate or maintain sufficient pressure, the main air line pressure is too low or the PowerPak hydraulic pressure requires adjustment. - Air pressure requirements: 1/2-inch (12.7mm) ID air line with 90 to 120 psi (0.62 to 0.83MPa). - Flow requirements: 40 to 50 cfm (1.13-1.42m³/min).



**Figure 5.0-5
PowerPak Pressure Adjustment**

SECTION 6.0: ILLUSTRATED PARTS BREAKDOWN

6.1 JUMBO BRUTE SERIES PULLER UNIT DIAGRAM

A diagram of the Jumbo Brute series Puller Unit is shown in Figure 6.1-1, which corresponds to the parts list in Table 6.2-1.

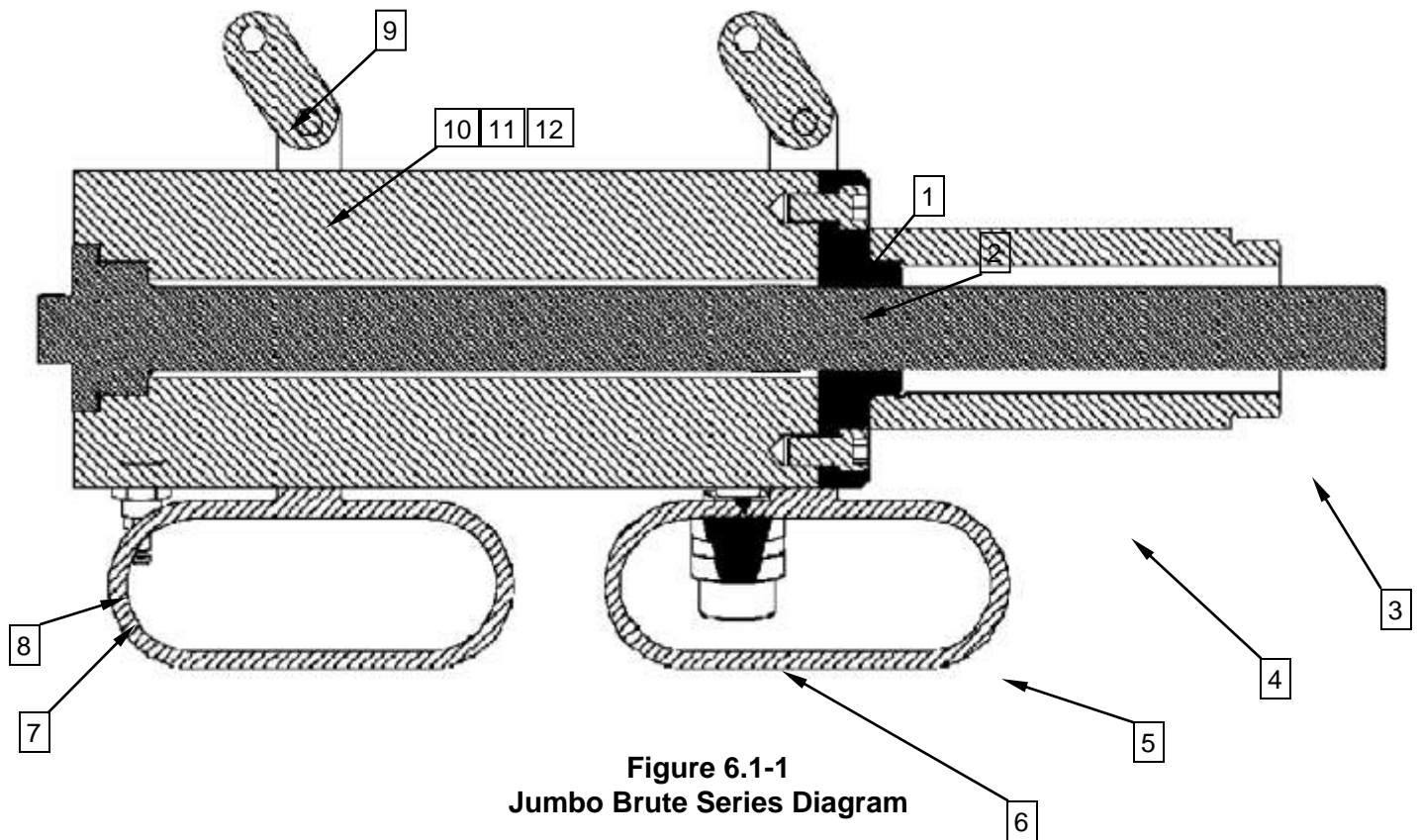

Figure 6.1-1
Jumbo Brute Series Diagram

6.2 JUMBO BRUTE SERIES PULLER UNIT ASSEMBLY PARTS LIST

The parts list in Table 6.2-1 corresponds to the drawing in Figure 6.1-1 on the previous page.

**Table 6.2-1
Jumbo Brute Series Parts List**

Reference Number	Description	Part Number	Notes
1	Faceplate (JB-30A, JB-60, JB-60C, and JB-60E)	5555-001	
	Faceplate (JB-60A)	5555-002	
	Faceplate (JB-60B and JB-60D)	5836-001	
	Faceplate (JB-30 and JB-30-968)	5836-002	
	Faceplate (JB-60D)	5555-001	
2	Screw (JB-30 series)	1039-003	
	Screw (JB-60 series)	1042-003	
3	Pull Rod (JB-30)	5559-003	
	Pull Rod (JB-30-968)	5559-004	
	Pull Rod (JB-30A)	5559-005	
	Pull Rod (JB-60 series)	5559-001	
4	Extension Tube (JB-60)	5500-001	1
	Extension Tube (JB-60A)	5500-002	1
	Extension Tube (JB-60B)	5837-001	1
	Extension Tube (JB-60C)	5928-001	1
	Extension Tube (JB-60D)	5803-001	1
	Extension Tube (JB-60E)	5500-003	1
5	Lifting Handle	1187-086	
6	Hydraulic Coupler	1047-013	
7	Air Coupler, Male	1047-036	
8	Adapter, Threaded	1047-029	
9	Link, Sling Attachment	3158-001	
10	Bolt	1187-099	
11	Washer	1187-097	
12	Nut	1187-098	
---	Trigger Assembly	2049-007	2
---	Air-Hydraulic Extension Hose Assembly	5628-001	2
---	Enerpac CT-604 Pressure Relief Tool	1187-770	2,3

Note 1: JB-30 series Puller Units do not have an Extension Tube

Note 2: Not shown in assembly illustration.

Note 3: Not included.

6.3 JUMBO BRUTE SERIES REMOTE TRIGGER ASSEMBLY; PARTS LIST

6.3.1 Jumbo Brute Series Remote Trigger Assembly

Fatigue Technology has redesigned the remote trigger assemblies to a cartridge trigger assembly. The new design will reduce the occurrence of trigger air leaks, perform more reliably (better pump actuation), and is easier to maintain. As of June 2005, all remote triggers will have the cartridge trigger assembly.

The previous trigger design detailed in Section 6.3.2 can be easily replaced with this improved trigger assembly. Two part numbers are needed for replacement:

- The Cartridge Trigger Assembly Kit (FTI-CT-RK)
- Puller Trigger Rework Tool Kit (FTI-CT-RKT).

One FTI-CT-RK kit is required for each puller converted. Only one FTI-CT-RKT is required regardless of the number of pullers converted. The FTI-CT-RKT kit includes the tools (punch, tap, etc.) required and detailed instructions on how to perform the modification.

Table 6.3.1-1
Parts List for Cartridge Trigger Assembly Kit

Quantity	Line Item	Description	FTI Part Number	Included in Kit #
1	1	Valve, Cartridge Trigger	1187-622	FTI-CT-RK
1	2	Spring, LB Handle	1187-623	FTI-CT-RK
1	3	Retainer, LB Handle	1187-624	FTI-CT-RK
1	4	Sleeve, Puller Handle	3196-001	FTI-CT-RK
1	5	Guard, Remote Trigger Handle	5193-001	None
2	6	Screw, 8-32UNC Modified, 3/16" Long	5195-001	None

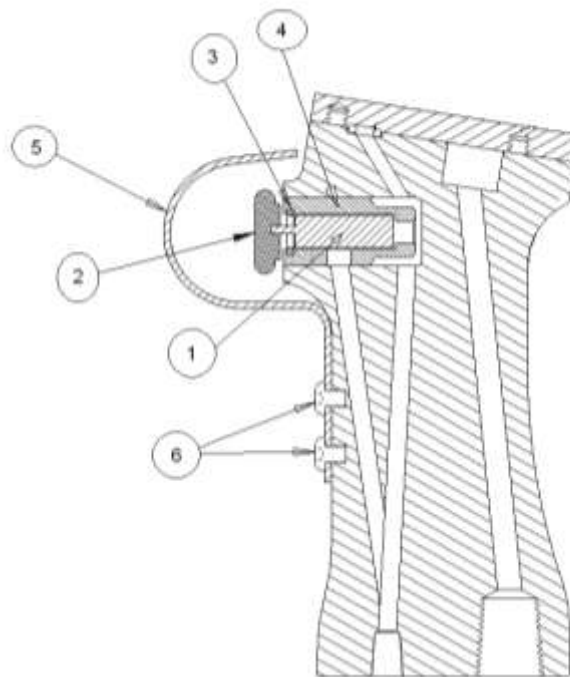

Figure 6.3.1-1
Diagram of Remote Trigger Assembly

6.3.2 Jumbo Brute Series Original Remote Trigger Assembly

Remote triggers purchased before June 2005 will have the following trigger assembly. These trigger assemblies can be readily identified by the aluminum pushbutton. (The new trigger assemblies have a brass pushbutton). If you have the previous trigger assembly, you can convert your trigger assembly by purchasing the Cartridge Trigger Assembly Kit (FTI-CT-RK) and the Puller Trigger Rework Kit (FTI-CT-RKT). The parts list below identifies the previous trigger assembly:

**Table 6.3.2-1
Parts List for Original Trigger Assembly**

Quantity	Line Item	Description	FTI Part Number
1	1	Trigger, LB Handle	2042-001
1	2	Spring, LB Handle	1005-003
1	3	Retainer, LB Handle	2043-001
1	4	Ball, .250 Dia. Stl.	1045-025
1	5	Pin, 1/8 x 3/4 Stdl. Spring	1045-026
1	6	Seal, LB Handle	2040-001
1	7	Sleeve, LB Handle	2044-001

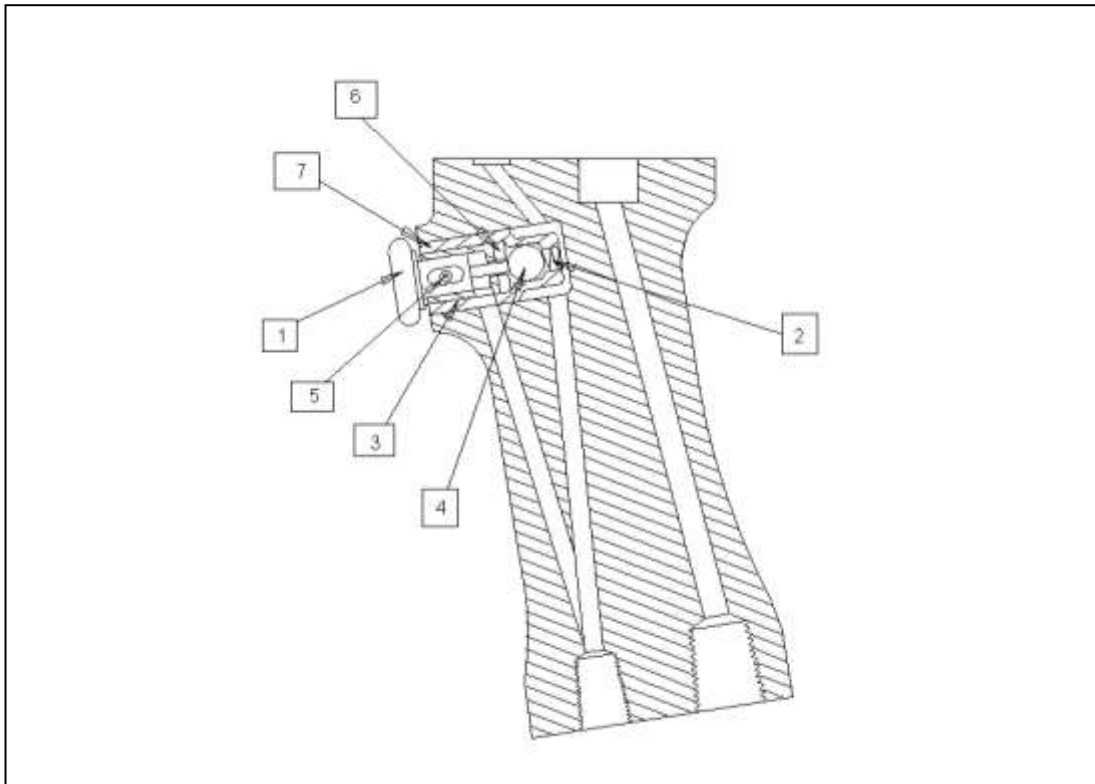

**Figure 6.3.2-1
Diagram of Original Trigger Assembly**



FATIGUE TECHNOLOGY
401 Andover Park East
Seattle, Washington 98188-7605
USA

E.C. DECLARATION OF CONFORMITY

Manufacturer: Fatigue Technology
401 Andover Park East
Seattle, WA 98188-7605

Telephone: (206) 246-2010
Fax: (206) 244-9886

Responsible Person in E.C.: Keith Huxley
FT-Ltd.
Rosevear
Level Road
Hawarden, Deeside CH5 3JR
United Kingdom

Telephone: 44 1244 538730
Fax: 44 1244 534423

The undersigned declares that the machinery described:

Type:

Serial Number:

conforms to the following directives:

Council Directive 2006/42/EC (the Machinery Directive)

EN 792-1 Hand-Held Non-Electric Power Tools – Part 1

EN 982 Safety Requirements for Fluid Power Systems and Their Components –
Hydraulics

EN 983 Safety Requirements for Fluid Power Systems and Their Components --
Pneumatics

and complies with the relevant health and safety requirements.

A handwritten signature in black ink, appearing to read 'Jeff Sageman', written over a horizontal line.

Jeff Sageman
Logistics Manager

January 17, 2014

Date

This page intentionally left blank for two-sided printing.