FTI OPERATIONS, MAINTENANCE, AND REPAIR MANUAL

Medium Brute Puller Unit

**Part #2720-007, Log #01204
Revision G**

February 8, 2017



Original Instruction

Fatigue Technology Inc. (FTI) is a world-leading aerospace engineering and manufacturing company. FTI pioneered cold expansion technology (which provides solutions to fatigue problems associated with holes in metal structures) back in 1969 and has advanced this science to develop innovative bushing and fastener products. These proprietary products and associated tooling may be covered by patents or agreements owned by, or exclusively licensed to Fatigue Technology Inc. Use of tooling procured from other than a licensed source may constitute patent infringement.

The detailed tooling information in this manual was compiled and written by FTI. The tooling was designed specifically for use with FTI's Cold Expansion (Cx™) Systems. FTI cannot be held responsible for damage or injury as a result of operating this equipment if it is used for other than the process intended, with any other tooling not provided by FTI, or not used in accordance with the instructions contained in this manual. To avoid personal injury, please observe all safety precautions and instructions. If you have any questions about the use or serviceability of this equipment, please contact our Sales Department.

FTI's systems and processes are the subject matter of one or more of the following patents: 4,809,420, 4,885,829, 4,934,170, 5,083,363, 5,096,349, 5,103,548, 5,127,254, 5,129,253, 5,218,854, 5,245,743, 5,305,627, 5,341,559, 5,380,136, 5,405,228, 5,433,100, 5,468,104, 6,077,010, 6,183,180, 6,487,767, 6,792,657, 6,990,722, 7,024,908, 7,100,264; 1,061,276, 513,898, 692015124, 581,385, 69310828, 468,598, 69105390, 643,231, 69414946, 696,686, 785,366, 1032769, and other patents pending. These systems and processes are tooling critical and must be performed in accordance with FTI's specifications or controlling documents. To ensure proper results from FTI's cold expansion systems and to be licensed to use FTI's patented processes, it is essential that FTI's complete integrated system of tooling be purchased and utilized. The use of tooling purchased from other than a licensed supplier could jeopardize fatigue life enhancement and may constitute patent infringement.

FTI reserves the right to change the specifications or configurations of tooling detailed in this manual as part of its ongoing technical and product information program. Should inconsistencies occur between your tooling and this manual, please contact our Sales Department.

ABOUT FATIGUE TECHNOLOGY INC.

Fatigue Technology Inc. (FTI) has provided innovative solutions to fatigue problems in metal structures since 1969. Complete systems of tooling are used worldwide to enhance the fatigue life of holes in airframes, turbine engines, and other critical structures.

The FTI staff of professionals provides a full range of support services, including:

- Application engineering
- Detailed project planning, implementation, and management
- On-site assistance, including training and tool room setup

The Sales Department is always available to assist with special fatigue enhancement requirements. Please contact FTI with questions at any time.

TABLE OF CONTENTS

SECTION	DESCRIPTION	PAGE
1.0	Introduction.....	1
1.1	About the Medium Brute Puller Unit.....	1
1.2	General Specifications.....	1
1.3	General Description.....	2
2.0	Safety.....	4
3.0	Puller Unit Operating Instructions.....	6
3.1	Puller Unit Setup Procedure.....	6
3.2	Actuation of the Puller.....	6
4.0	Maintenance.....	7
4.1	General Cleaning.....	7
4.2	Lubrication.....	7
4.3	Inspection.....	7
4.4	Assembly and Disassembly.....	7
5.0	Troubleshooting.....	9
5.1	PowerPak Will Not Build Full Hydraulic Pressure.....	9
5.2	Puller Retracts on First Trigger Actuation, But Will Not Return to Start Position.....	10
5.3	PowerPak Will Not Generate Constant Pressure (Hiccups).....	11
5.4	PowerPak Will Not Operate or Maintain Sufficient Pressure (6,000 psi).....	12
5.5	Mandrel Sticks in Hole When Puller Is Activated.....	13
6.0	Illustrated Parts Breakdown.....	14
6.1	Medium Brute Rework Kit (FTI-CT-RK and MB-CT-RK).....	14
6.2	Medium Brute Seal Kit (MB-SK) MB-30 and MB-70 Variants.....	15
6.3	Previous Trigger Assembly.....	16
6.4	Medium Brute Parts List; MB-30 and MB-70 Variants.....	17
6.5	Medium Brute Parts List; BMB-10.....	19

TABLE OF CONTENTS (Continued)

SECTION	DESCRIPTION	PAGE
FIGURES		
Figure 1.3-1	Medium Brute Puller Unit Parts.....	2
Figure 1.3-2	Medium Brute Puller Unit Specifications.....	3
Figure 2.0-1	Safety Stickers	4
Figure 2.0-2	Location of Air Disconnect.....	4
Figure 5.1-1	FT-20 PowerPak	9
Figure 5.1-2	FT-200 PowerPak	9
Figure 5.2-1	Hydraulic Quick Coupler.....	10
Figure 5.2-2	Enerpac CT-604 Pressure Relief Tool	10
Figure 5.3-1	Trigger Response Valve (FT-200) Location.....	11
Figure 5.3-2	Trigger Response Valve (FT-20) Location.....	11
Figure 5.4-1	Pressure Gage (FT-200) Location.....	12
Figure 6.1-1	Diagram of Cartridge Trigger Assembly	14
Figure 6.2-1	Medium Brute -30 and -70 Variants Seal Kit.....	15
Figure 6.3-1	Diagram of Previous Trigger Assembly	16
Figure 6.4-1	Medium Brute -30 and -70 Variants Assembly Diagram	18
Figure 6.5-1	Medium Brute BMB-10 Assembly Diagram	20
	E.C. Declaration of Conformity	21
TABLES		
Table 1.3-1	Medium Brute Specifications	3
Table 6.1-1	Medium Brute Rework Kit	14
Table 6.2-1	Medium Brute -30 and -70 Variants Seal Kit (MB-SK).....	15
Table 6.3-1	Parts List for Previous Trigger Assembly.....	16
Table 6.4-1	Medium Brute -30 and -70 Variants Parts List.....	17
Table 6.5-1	Medium Brute BMB-10 Parts List.....	19

SECTION 1.0: INTRODUCTION

This instruction manual contains information on the operation and maintenance of the Medium Brute Puller Unit. To obtain optimum performance and many years of trouble-free service, operate the puller unit properly and carefully follow maintenance procedures. **Read this manual before operating the puller unit**, and retain the manual for future reference. If requested, FTI will provide this manual in the language of the end-user.

1.1 ABOUT THE MEDIUM BRUTE PULLER UNIT

The Medium Brute hydraulic puller unit is a powerful, moderately sized, lightweight tool specifically designed for use with FTI's patented Split Sleeve Cold Expansion process. The Medium Brute is designed to pull a mandrel through a hole with the pre-lubricated stainless steel split sleeves used in this process.

The MB pullers have a maximum pull force of 24,000 pounds ($1.1 \times 10^5 \text{N}$) at 10,000 psi (689.5 bar) pump pressure. The MB is available in sizes (models) capable of cold expanding holes up to 1 inch (25.4 mm) in diameter and 7 inches (177.8 mm) deep in aluminum, and up to 7/8-inch (22.2 mm) diameter in steel and titanium.

The Medium Brute is available in various models to accommodate multiple material stack-ups, hose options, and mandrel adapters:

- MB-xx where '-xx' relates to material stack (see Table 1.3-1)
- MB-xx-V where '-V' represents high visibility hoses
- MB-xx-Hxx where '-Hxx' represents a unique hose length other than the standard 10 feet
- MB-xxA comes with a MB-CA-8 mandrel adapter
- MB-xxB comes with a MB-CA-11 mandrel adapter

The Medium Brute has a fail-safe air control system that causes the puller retraction cycle to be interrupted whenever the operator releases finger pressure on the trigger or in the event of air or hydraulic hose failure. All puller units operate in conjunction with either of FTI's PowerPak air-hydraulic power units, the standard FT-200 or portable FT-20 (and are compatible with older units IW100MF and IW10MF). The MB has proven to be very reliable and requires minimal maintenance.

1.2 GENERAL SPECIFICATIONS

Hydraulic Fluid Requirements	U.S. MIL-Spec #5606
Air Line Requirements.....	3/8 to 1/2 inch (9.5 to 12.7 mm) ID
Air Flow Requirements (via PowerPak)	45 cfm (1274.3 liter/minute)
Stackup Capacity (Grip)	Material up to 7 inches (177.8 mm)
Actuation / Operation.....	Pneumatic / Hydraulic
Compatible PowerPaks	FT-200 or FT-20
Fail-safe	Air logic safety circuit halts mandrel retraction when trigger is released
Replacement Seal Kit.....	Medium Brute Seal Kit (MB-SK)
Weight (without tooling)*	
MB-30.....	20 pounds
MB-70.....	24 pounds
BMB-10	19 pounds
Emission sound pressure level at the work station (according to EN ISO 11201:1995) on load	83.1 dB(A)
Weighted hand-arm vibration at the handle (according to EN 28662-1:1993) on load	<2.5 m.S ²

*A user-supplied suspension system may be required at the end use site. The requirement for a suspension system is based on the end user's workplace lifting and weight standards. A risk analysis for the suspension is necessary to maintain compliance to end user's standards or directives. All risks involved with the suspension of the Medium Brute are the responsibility of the end user. User instructions and training regarding the suspension system are the responsibility of the end user.

1.3 GENERAL DESCRIPTION

- Air actuated, hydraulic puller is capable of cold expanding up to 15/16-inch (23.8 mm) diameter in aluminum and mild steel, and up to 3/4-inch (19.1 mm) diameter in titanium and high-strength steel.
- Maximum pull force is 24,000 pounds (1.1×10^5 Newtons) at 10,000 psi (389.5 bar) of hydraulic pressure.
- Includes a 10-foot (3 meters) hose assembly, spanner wrench, nosecap pin wrench, and alternate 7/8-inch (22.2 mm) threaded adapter for larger mandrel sizes.
- Available in 16.7 to 24.0 inch (0.4 to 0.6 meter) overall lengths depending on the model.
- Up to 7.0 inches (177.8 mm) material stackup capacity.
- Hydraulic pressure provided by the FT-200 or FT-20 PowerPak.



Figure 1.3-1
Medium Brute Puller Unit Parts

**Table 1.3-1
Medium Brute Specifications**

Model Number	Maximum Material Stackup	L (Reference Section 2.2*)	F (Reference Section 2.2*)	Weight	Stroke
MB-30	3.3 inches 83.8 mm	18.2 inches 462.3 mm	8.6 inches 218.4 mm	20 lbs 9.1 kg	5.2 inches 132.1 mm
MB-70	7.0 inches 177.8 mm	25.5 inches 647.7 mm	11.6 inches 294.6 mm	24 lbs 10.9 kg	8.9 inches 226.1 mm
BMB-10	1.0 inch 25.4 mm	15.7 inches 398.8 mm	7.1 inches 180.3 mm	19.2 lb 8.71 kg	3.16 inches 80.3 mm

*Refers to the FTI Tooling Catalog, current revision.

Nosecap Selection: The Medium Brute Puller Unit is compatible with both the standard nose caps or the extension nose caps (Section 2*).

Mandrel Selection: The Medium Brute Puller Unit is directly compatible with standard Type 2 or Type 5 threaded mandrels (Section 2*).

* Refers to the FTI Tooling Catalog, current revision.

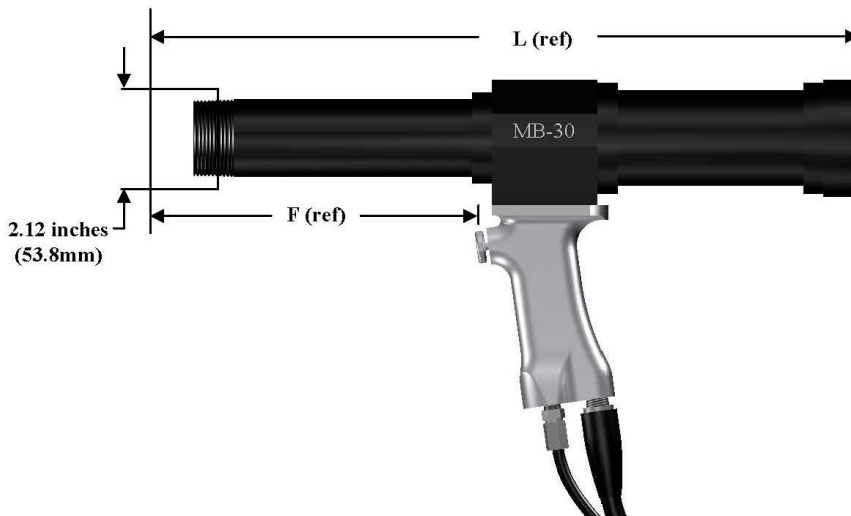

**Figure 1.3-2
Medium Brute Puller Unit Specifications**

SECTION 2.0: SAFETY

Consult PowerPak manual for safety precautions before connecting the puller unit.

When used in accordance with these instructions, the puller unit is safe and easy to use. All general safety precautions associated with hydraulic and pneumatically operated power tools should be observed. Many of these are noted in this section. Ultimately, the operator is responsible for personal safety; however, the following general safety precautions should be observed.

CAUTION: The weight of this unit may require a suspension system per the end-user's workplace lifting standards.

1. Wear eye and ear protection when operating the puller unit. See the safety stickers shown in Figure 2.0-1.

Read manual before using

Always wear eye protection

Always wear ear protection



**Figure 2.0-1
Safety Stickers**

2. Disconnect the air supply when:
 - Maintenance is to be performed.
 - Hydraulic hose is disconnected.
 - PowerPak is not in use.
3. In the event of a ruptured or leaking hydraulic hose, **IMMEDIATELY RELEASE THE TRIGGER AND DISCONNECT THE AIR LINE** from the PowerPak at the air coupler (see Figure 2.0-2). **Never use your hands** to grasp a leaking hose under pressure. The force of escaping hydraulic fluid could cause serious injury. If hydraulic oil should penetrate the skin, medical attention must be sought immediately.
4. Keep hands away from noscap assembly while holding noscap against the workpiece.
5. Release puller unit trigger when mandrel clears the workpiece, or becomes stuck.
6. The end cap must always be in place while in use. Injury may occur if end cap is removed during operation. All new puller units have been modified to ensure operator safety. However, rework instructions are available from FTI for any Medium Brute Puller Units that do not have a role pin and air seal adapter like that shown in Figure 6.3-1.



**Figure 2.0-2
Location of Air Disconnect**

7. Before operating the pump, tighten all hose connections using the proper tools. Do not overtighten the connections. Connections need only be tightened securely and leak-free. Overtightening may cause premature thread failure or high-pressure fittings to split at pressures lower than their rated capacities.
8. Operators must read this manual in its entirety before using the Medium Brute. Eye and ear protection must be worn while operating the Medium Brute. Three safety stickers on the Medium Brute act as a reminder to these instructions. The symbols are shown in Figure 2.0-1.

Hydraulic Hose Safety

9. Inspect hydraulic hose for signs of wear (cuts, abrasions, or kinks) to the outer shell materials. Pump clean oil through the entire length. Pressurize the hose and check for leaks at the crimped connectors, between the hose material and the fitting, and between the fitting and the coupler.
10. **DO NOT** attempt to disconnect the hydraulic hose while it is under pressure.
11. **DO NOT** expose hoses to potential hazards such as extreme heat or cold, sharp surfaces, or heavy impact.
12. **DO NOT** allow hoses to kink, twist, curl, or bend so tightly that the oil flow within the hose is blocked or reduced. Periodically inspect the hose and fittings for wear or damage that could cause premature failure of the hose or fittings and possibly result in injury. Damaged hoses must be replaced immediately.
13. **DO NOT** use the hose to move attached equipment.
14. **DO NOT** remove strain reliever from hoses.
15. Do not use in potentially explosive atmospheres.
16. Hose strain relievers must be placed around hose fittings during use. Hoses with damaged strain relievers must be replaced immediately.
17. Hose material and coupler seals must be compatible with hydraulic fluid that meets the requirements of U.S. MIL-SPEC #5606.
18. Hoses must not come in contact with toxic materials such as creosote-impregnated objects and some paints. Keep couplers and hoses clean and free of paint. Hose deterioration due to chemical degradation may cause the hose to fail under pressure. Damaged hoses must be replaced immediately.
19. Before operating pump, make sure all hose connections are tightened securely. **DO NOT** overtighten.
20. If hoses require replacement contact the FTI Sales Department.

IMPORTANT: FTI completed a risk assessment on this unit at our factory. Any modifications done by a third party or the final user are excluded from that risk assessment. As a result, modifications done by a third party or the final user nullify the CE marking.

SECTION 3.0: PULLER UNIT OPERATING INSTRUCTIONS

Become familiar with these instructions before operating the puller.

3.1 PULLER UNIT SETUP PROCEDURE

Refer to Section 6.0 (Illustrated Parts Breakdown) for parts identification.

1. Inspect all threads and fittings of PowerPak for signs of wear or damage and replace them if necessary.
2. Uncoil the hose assembly of the puller unit, and inspect all threads, couplings, and hoses for damage and degradation.
3. If the chuck assembly/adaptor (see Table 6.4-1, Reference Number 8) needs to change, remove the front barrel by loosening the barrel lockring (Reference Number 11), and unthread the barrel, thread on the appropriate adaptor, and reattach the barrel.
4. Remove the thread protectors from the hydraulic fittings and thread the hydraulic hose fitting from the puller unit (female) onto the hydraulic fitting of the FTI PowerPak (male). Wipe fittings clean prior to connecting. Make sure to thread couplers completely together. There should be positive contact between the PowerPak coupler and the hose fitting flange. Failure to completely tighten the coupler will prevent the puller from returning to the forward (start) position. See Section 5.0, Problem 5.2, for more information.
5. Connect the male/female air quick-disconnects from the puller unit to the FTI PowerPak.
6. Test shop air supply to ensure that it is clean, dry, and between 90 and 120 psi (6.2 and 8.3 bar) at 45 cfm (1274.3 liter/minute).
7. Connect the female quick-disconnect of a 3/8-inch or 1/2-inch (9.5 mm or 12.7 mm) inside diameter shop air line onto the male air inlet of the PowerPak.
8. Install the appropriate mandrel into the threaded adaptor (hand tight).
9. Install the appropriate nosecap assembly over the mandrel and thread onto the barrel (hand tight).

3.2 ACTUATION OF THE PULLER

1. The puller unit can be activated only when connected to an FTI PowerPak.
2. Activate the puller unit by depressing the trigger on the handle. Hydraulic pressure is transmitted through the hose to the cylinder of the puller unit which then retracts the hydraulic piston.
3. Releasing the trigger changes pressure at the pilot valve to stop the pull cycle and return the puller unit to its original position.
4. If the puller unit fails to operate as detailed above, refer to Section 5.0 (Troubleshooting).

SECTION 4.0: MAINTENANCE

The puller unit requires routine checking and periodic preventative maintenance to ensure safe, trouble-free operation. No special maintenance is required. The following maintenance actions are suggested.

WARNING
Disconnect the PowerPak from the air supply before performing maintenance or repair procedures.

4.1 GENERAL CLEANING

1. Periodically clean the outer surfaces of the puller unit and PowerPak.
2. When not in use, ensure thread protectors are reinstalled.
3. Keep all hose connections free of dirt and grime.

4.2 LUBRICATION

1. There is no internal lubrication requirement for the puller unit.
2. Whenever the puller unit is to be stored for any length of time, maintain a thin coat of 10-weight oil on the outside of black oxidized surfaces.

4.3 INSPECTION

Periodically inspect the threaded fittings for cracks, leaks, or other damage. Repair and replace as necessary.

4.4 ASSEMBLY AND DISASSEMBLY

Normal replacement of seals (refer to the Illustrated Parts Breakdown, Figure 6.4-1).

Disassembly

1. Unthread and remove the nose cap assembly.
2. Unthread and remove the mandrel from the threaded adapter.
3. Loosen the lockring (7) to remove tension from the end cap (6) and cylinder (3).
4. Unthread and remove the end cap (6).
5. Unscrew and remove the rear cylinder (3) and front cylinder (5) from the housing (9).
6. Unthread and remove the threaded adapter (8).

7. Unthread and remove the threaded adapter (8) from the piston rod. Since it is necessary to hold the piston rod stationary to remove the locknut (10), use a screwdriver in the slot (some old models have a hex wrench hole) in the back end of the piston to keep the piston rod from turning.

DO NOT scratch the piston shaft during disassembly.

Note: Your MB was shipped with a 5/8-inch (15.9 mm) diameter threaded adapter installed and a 7/8-inch (22.2 mm) diameter threaded adapter.

8. Remove the piston rod assembly (4) by pushing on the threaded end (nosecap end) of the piston rod until the threads engage the sleeve (2). Thread the piston rod through the sleeve and remove the piston rod assembly.
9. Remove the brass sleeve (2).
10. Remove the handle assembly (12) by removing the four hex-head bolts.

Reassembly

**Important: (1) Thoroughly clean all parts prior to reassembly.
(2) Install O-Rings toward hydraulic flow, with Teflon backup rings “behind.”**

1. Replace O-Rings and backup rings on the brass sleeve (2). Drop into the front of the housing (9).
2. Replace the rear cylinder (3) and tighten until snug. Tighten the lockring (7).
3. Replace O-Rings and backup rings on the air seal adapter on the end of the piston assembly (4).
4. Install the threaded end of the piston assembly (4) into the housing (9). Thread the piston through the housing and push to the full forward position.
5. Install the handle assembly (12) onto the housing using the four hex-head bolts.
6. Install the threaded adapter (8).
7. Install the front barrel (5).
8. Install the end cap (6) and tighten the lockring (7).
9. Select the appropriate mandrel/nosecap combination and install.

SECTION 5.0: TROUBLESHOOTING

This section provides solutions to some basic trouble spots. If you cannot solve your maintenance or operational problems with the information provided in this section, contact the nearest FTI representative.

Note: Should difficulties originate in the PowerPak, consult the specific PowerPak Operations, Maintenance, and Repair Manual.

<u>PROBLEM</u>	<u>CAUSE</u>	<u>SOLUTION</u>
----------------	--------------	-----------------

5.1 POWERPAK WILL NOT BUILD FULL HYDRAULIC PRESSURE

- | | |
|--|---|
| (a) One or more of the key air or hydraulic lines has not been securely connected. | (a) Check the following hose connections: <ol style="list-style-type: none">1. Male air line quick-disconnect fitting from shop air system to PowerPak.2. Hydraulic quick couplings connecting the hoses to the PowerPak manifold, and the puller to the hydraulic hoses. See Figures 5.1-1 and 5.1-2.3. Two male/female air line quick-disconnect fittings connecting the puller to the PowerPak manifold.4. Check that the main air supply has not been interrupted. |
|--|---|

CAUTION

Hydraulic oil under extreme pressure may cause serious injuries if not handled carefully. For technical assistance, please contact the FTI Sales Department.

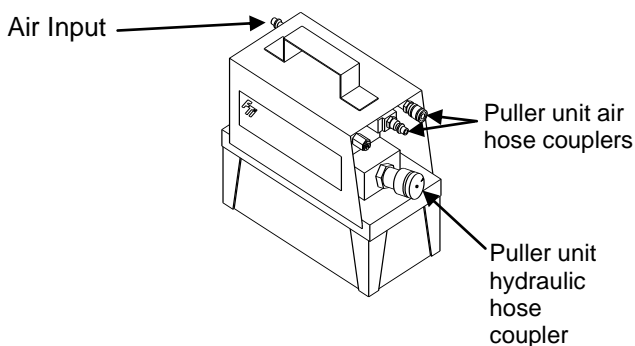

**Figure 5.1-1
FT-20 PowerPak***

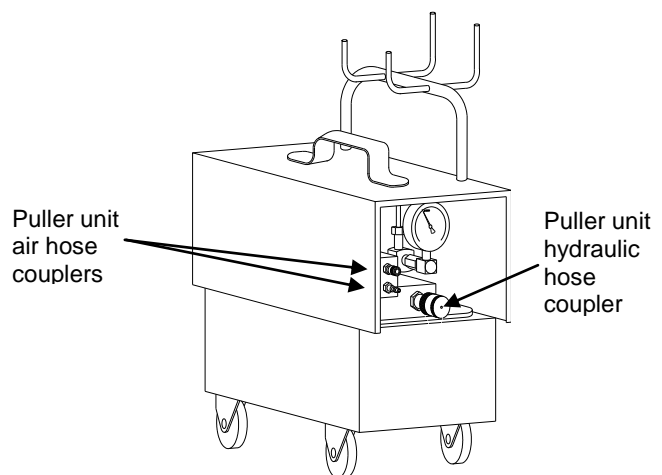

**Figure 5.1-2
FT-200 PowerPak***

* PowerPak drawings are not to scale.

PROBLEM

CAUSE

SOLUTION

5.2 PULLER RETRACTS ON FIRST TRIGGER ACTUATION, BUT WILL NOT RETURN TO START POSITION

(a) The new puller unit requires lubrication through the piston and cylinder.

(a) Keeping the air and hydraulic lines connected, remove the back end cap on the Medium Brute. Use a screwdriver and the screwdriver slot in the piston to push the piston rod forward. This should be somewhat easy. Reinstall the back end cap. Once forward, cycle the trigger several times – DO NOT bottom it out – to introduce hydraulic fluid into the cylinder (20+ short cycles).

b) As above, AND the hydraulic hose is difficult to bend or coil (indicating unrelieved pressure built up in the hose).

(b) The hydraulic quick coupler line has not been completely tightened at the PowerPak manifold (there should be no space between the PowerPak coupler and the hose fitting flange). See Figure 5.2-1.

(b) Once hydraulic pressure has been introduced to the hydraulic hose, the pressure must be relieved before the coupler can be sufficiently tightened.

Procedure for relieving hydraulic pressure:

1. Disconnect the main air supply.
2. Disconnect the coupler from the PowerPak.
3. Connect Enerpac CT-604 to the coupler and bleed off hydraulic oil to relieve the built-up pressure. Figure 5.2-2 shows the Enerpac CT-604 Pressure Relief Tool.
4. Once pressure is relieved, the coupler may be tightened and reinstalled onto the PowerPak.
5. Re-attach air lines to get the puller unit to return.

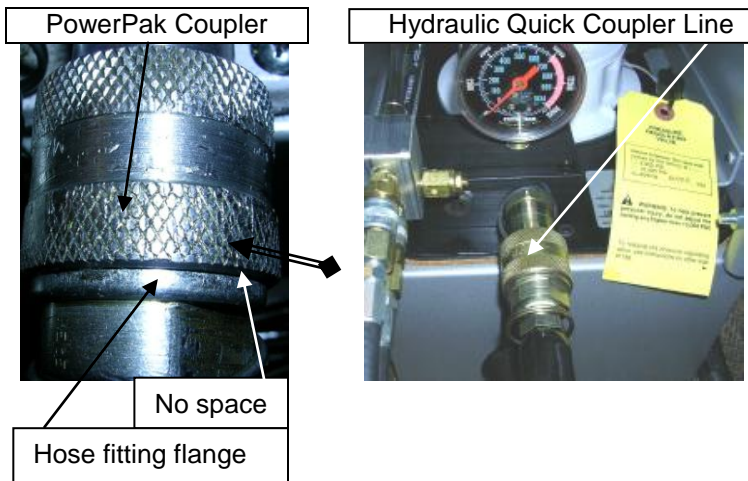

**Figure 5.2-1
Hydraulic Quick Coupler**



**Figure 5.2-2
Enerpac CT-604
Pressure Relief Tool**

PROBLEM

CAUSE

SOLUTION

5.3 POWERPAK WILL NOT GENERATE CONSTANT PRESSURE (HICCUPS)

(a) Trigger response valve requires adjustment. See Figures 5.3-1 and 5.3-2.

(a) Adjustment procedure:

1. Loosen the locknut on the trigger response valve.
2. Using a screwdriver, open the screw counterclockwise until the PowerPak will not start when the puller unit trigger is depressed.
3. Turn screw clockwise until:
 - PowerPak generates constant pressure when puller trigger is depressed, and
 - PowerPak starts instantly when puller trigger is depressed and stops instantly when released. When the puller unit trigger is depressed, the PowerPak should be run at the pre-set pressure until the trigger is released.
4. Hold the set screw in position and tighten the locknut.

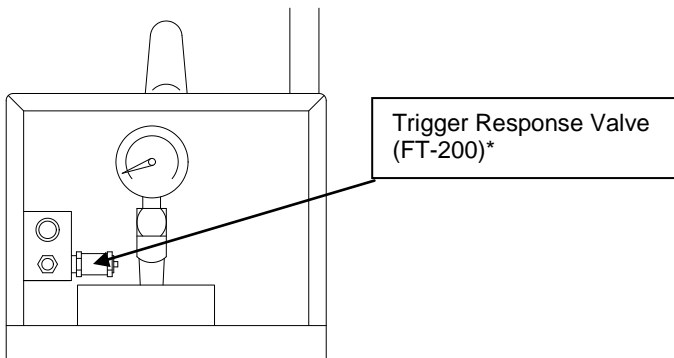

**Figure 5.3-1
Trigger Response Valve (FT-200) Location**

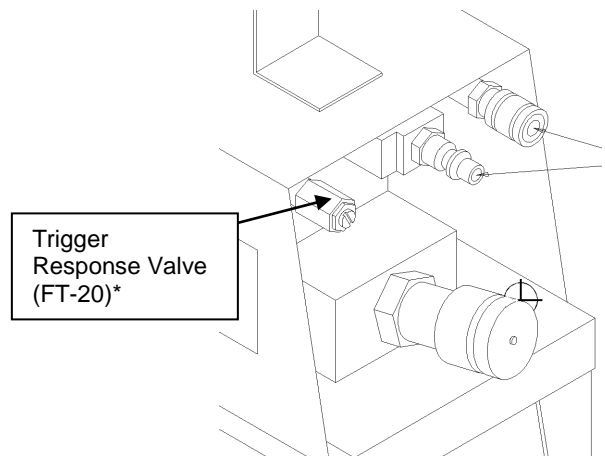

**Figure 5.3-2
Trigger Response Valve (FT-20) Location**

*PowerPak drawings are not to scale.

**5.4 POWERPAK WILL NOT OPERATE OR MAINTAIN SUFFICIENT PRESSURE
(6,000 PSI, 413.7 BAR)**

(a) Hydraulic pressure requires adjustment (FT-200 PowerPak only). See Figure 5.4-1.

(b) Inadequate air supply.

(a) Adjust PowerPak pressure valve:

1. Squeeze the trigger on the puller unit to activate the PowerPak.
2. If pressure does not reach 6,000 psi (413.7 bar), loosen the wingnut and turn the hydraulic pressure control clockwise until pressure reaches 6,000 psi (413.7 bar).
3. Tighten the locknut to secure available shop air.

(b) Increase the pressure or flow of available shop air.

If the PowerPak will not generate or maintain sufficient pressure, the main air line pressure is too low or the PowerPak hydraulic pressure requires adjustment.

Air pressure requirements:

-1/2-inch (12.7 mm) inside diameter air line with 90 to 120 psi for the FT-200

-3/8-inch (9.5 mm) inside diameter air line with 90 to 120 psi (6.2 to 8.3 bar) for the FT-20

Air flow requirements:

-40 to 50 cfm (1274.3 to 1415.9 liter/minute) for the FT-200

-20 cfm (566.3 liter/minute) for the FT-20

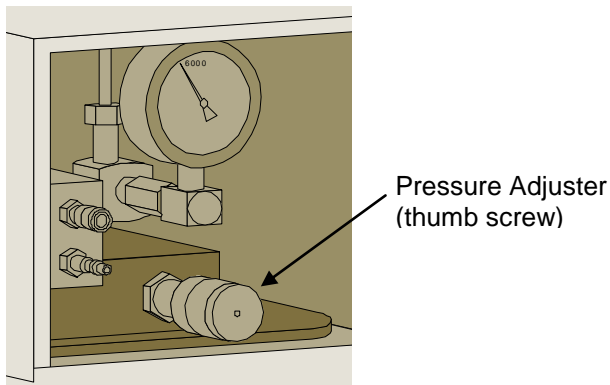

**Figure 5.4-1
Pressure Gage (FT-200) Location**

* Drawings not to scale

PROBLEM

CAUSE

SOLUTION

5.5 MANDREL STICKS IN HOLE WHEN PULLER IS ACTIVATED

- | | |
|--|---|
| <p>(a) Not enough pressure used to generate pull forces. If the Medium Brute is being used with the FT-20 PowerPak, proceed to solution 4.</p> | <p>(a) Use the following procedure to analyze the problem:</p> <ol style="list-style-type: none">1. Activate the puller unit and observe the pressure reading on the PowerPak pressure gage (FT-200 PowerPak only).2. The pressure gage should read 6,000 psi (413.7 bar). (Note: The FT-20 PowerPak is factory set at 10,000 psi or 689.5 bar). If an increase in pressure is required, refer to the solution for Problem 5.4 in this section for instructions.3. Activate the puller unit again. If mandrel remains stuck, increase pressure to 10,000 psi (689.5 bar).4. If mandrel remains stuck at 10,000 psi (689.5 bar), immediately disengage the mandrel from the puller unit. Push the mandrel out using an impact hammer. Contact the FTI Sales Department for additional assistance. |
|--|---|

SECTION 6.0: ILLUSTRATED PARTS BREAKDOWN

FTI has redesigned the puller unit trigger assembly, built with serial number 810 or higher, to a cartridge trigger assembly. The new design will reduce the occurrence of trigger air leaks, perform more reliably (better pump actuation), and be easier to maintain.

The previous trigger design detailed in Section 6.3 can be easily replaced with this improved trigger assembly detailed in Section 6.1. Two part numbers are needed for replacement:

- Either the Cartridge Trigger Assembly Kit (FTI-CT-RK) or the Medium Brute Rework Kit (MB-CT-RK) – (see kit differences in Table 6.1-1), and
- Puller Trigger Rework Tool Kit (FTI-CT-RKT).

One FTI-CT-RK or MB-CT-RK kit is required for each puller unit converted. Only one FTI-CT-RKT is required regardless of the number of pullers converted. The FTI-CT-RKT kit includes the tools (punch, tap, etc.) required and detailed instructions on how to perform the modification.

6.1 MEDIUM BRUTE REWORK KIT (FTI-CT-RK and MB-CT-RK)

This kit is used to repair or refurbish older pullers. Table 6.1-1 is a parts list for the Medium Brute Rework Kit and Figure 6.1-1 shows a diagram of the cartridge trigger assembly.

**Table 6.1-1
Medium Brute Rework Kit**

Quantity	Piece Number	Description	FTI Part Number	Included in Kit
1	Not Pictured	Screw, SHG (10-32 UNFX 3/4)	1029-005	MB-CT-RK
1	Not Pictured	MB-H-D16 Hydraulic Adapter	2039-002	MB-CT-RK
1	See Section 6.2	Medium Brute Seal Kit (MB-SK)	8000-485	MB-CT-RK
1	1	Cartridge Valve	1187-622	MB-CT-RK and FTI-CT-RK
1	2	Push Button, Brass	1187-623	MB-CT-RK and FTI-CT-RK
1	3	Retaining Ring, Internal	1187-624	MB-CT-RK and FTI-CT-RK
1	4	Sleeve, Puller Handle Trigger	3196-001	MB-CT-RK and FTI-CT-RK

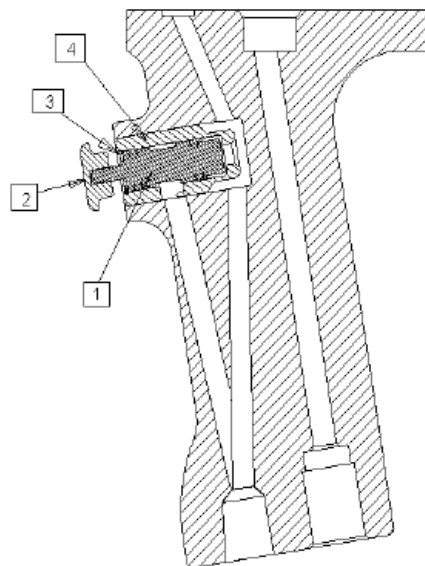

**Figure 6.1-1
Diagram of Cartridge Trigger Assembly**

6.2 MEDIUM BRUTE SEAL KIT (MB-SK) MB-30 AND MB-70 VARIANTS

This kit is used to replace seals in the MB-30 and MB-70 variants. It is included as part of the Medium Brute Rework Kit (see Section 6.1). Table 6.2-1 is a parts list for the Medium Brute Seal Kit.

See BMB-10 Parts List (Table 6.5-1) for itemized seals.

**Table 6.2-1
Medium Brute -30 and -70 Variants Seal Kit (MB-SK)**

Quantity	Description	FTI Part Number	Piece Number
1	Valve, Cartridge Trigger (See Figure 6.1-1, Piece Number 1)	1187-622	
1	Seal, LB Handle (See Table 6.3-1, Piece Item 6)	2040-001	
2	Ring, Backup MS28782-7	1046-044	1
2	O-Ring AN6227B-7	1046-045	2
1	O-Ring AN6227B-3	1046-012	3
1	O-Ring MS28775-224	1046-058	4
1	O-Ring AN6227B-17	1046-002	5
2	MS2878217 Ring, Backup	1046-003	6
1	17149-122	1046-043	7
1	A-122-90-BUNA	1046-007	8
1	AN6227-28	1046-004	9
1	MS28782-28	1046-005	10
1	T-Seal TPO23	1046-113	11

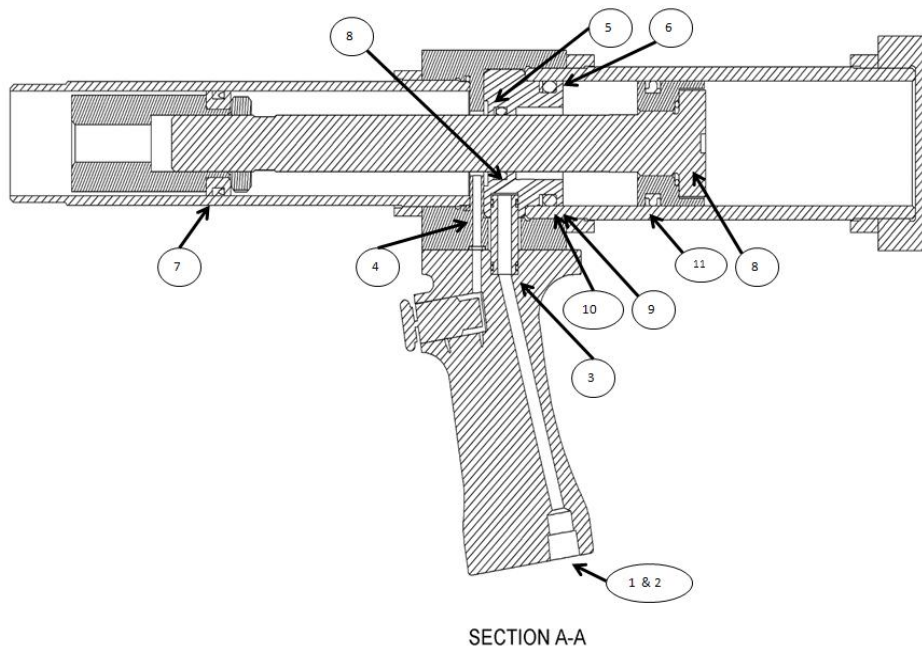

**Figure 6.2-1
Medium Brute -30 and -70 Variants Seal Kit**

6.3 PREVIOUS TRIGGER ASSEMBLY

The previous trigger design (serial numbers smaller than 810) detailed here can be easily replaced with the improved trigger assembly detailed in Section 6.1. Table 6.3-1 is a parts list for the old-style trigger assembly.

**Table 6.3-1
Parts List for Previous Trigger Assembly**

Quantity	Piece Item	Description	FTI Part Number
1	1	Trigger, LB Handle	2042-001
1	2	Spring, LB Handle	1005-003
1	3	Retainer, LB Handle	2043-001
1	4	Ball, .250 Diameter, stl.	1045-025
1	5	Pin, 1/8 x 3/4 stdl. Spring	1045-026
1	6	Seal, LB Handle	2040-001
1	7	Sleeve, LB Handle	2044-001

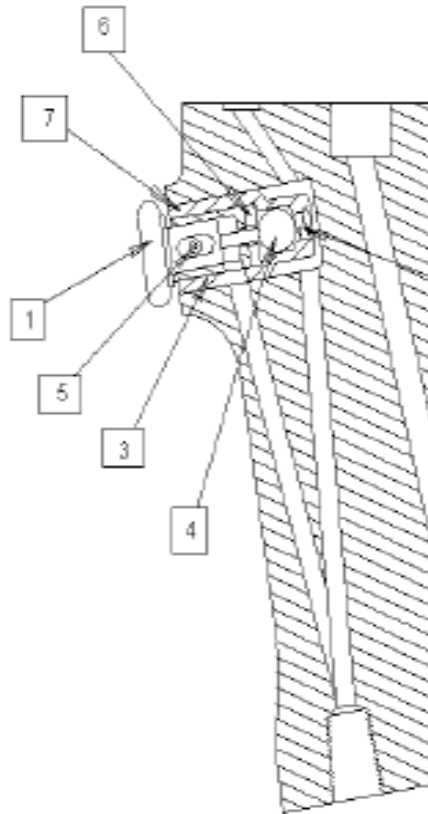

**Figure 6.3-1
Diagram of Previous Trigger Assembly**

6.4 MEDIUM BRUTE PARTS LIST MB-30 AND MB-70 VARIANTS

**Table 6.4-1
Medium Brute -30 and -70 Variants Parts List**

Reference Number	Description	Applicable Puller Unit	Part Number	Reference Information
2	Sleeve	All	MB-D2	
3	Cylinder	MB-30 variants	MB-30-D3	
		MB-70 variants	MB-70-D3	
4	Piston Assembly	MB-30 variants	MB-30-D4	
		MB-70 variants	MB-70-D4	
5	Barrel	MB-30 variants	MB-30-D5	
		MB-70 variants	MB-70-D5	
6	End Cap	All	MB-D6	
7	Cylinder Lockring	All	MB-D7	
8	Tang Mandrel Adapter	All	MB-CA-*	
	Threaded Mandrel Adapter, 5/8"	All	MB-D17	
	Threaded Mandrel Adapter, 7/8"		MB-D18	
9	Housing	All	MB-D10	
10	Locknut Adapter	All	MB-D14	
11	Barrel Lockring	All	MB-D16	
12	Handle Assembly	All	MB-H-1	
13	Hydraulic Hose Assembly	All	IWHH-10	
14	O-Ring	All	1046-002	AN6227-17
15	Backup Ring	All	1046-003	MS28782-17
16	O-Ring	All	1046-004	AN6227-28
17	Backup Ring	All	1046-005	MS28782-28
18	O-Ring	All	1046-058	MS28775-224
19	O-Ring	All	1046-007	A-122-90-BUNA
20	Warning Label	All	1009-185	
21	FTI Label	All	1009-094	
22	"Do Not Strike" Label	All	1009-184	
23	Heat Shrink Tube (3" long)	All	2638-001	
24	Air Hose Assembly (Male)	All	2106-001	
25	Air Hose Assembly (Female)	All	2106-002	
26	MB Puller Label	All	1009-187	
--	Pressure Relief Tool	All	1187-770	Not included

* Part number is dependent on which mandrel tang size is being used. Contact FTI's Sales Department for assistance.

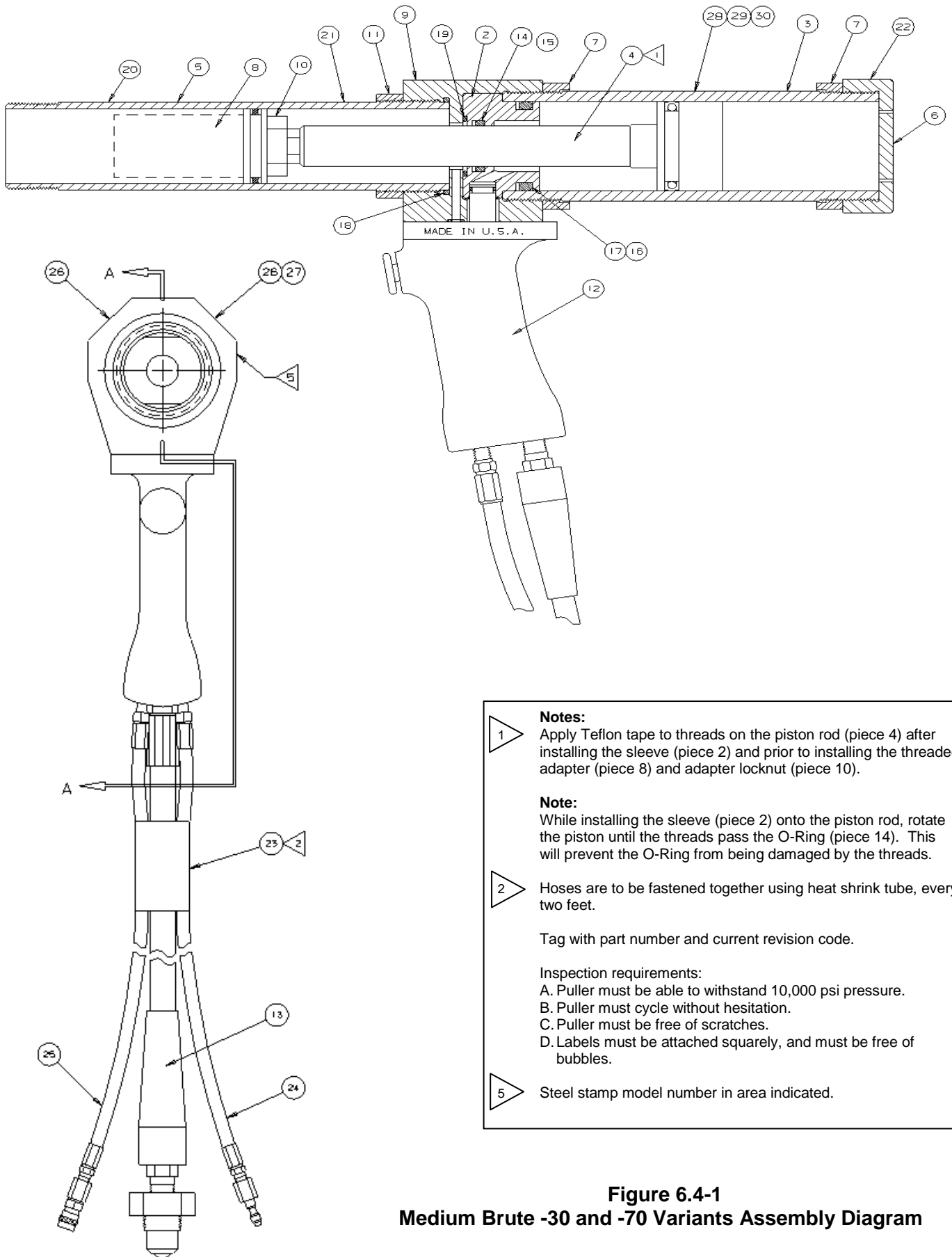

- Notes:**
- 1 Apply Teflon tape to threads on the piston rod (piece 4) after installing the sleeve (piece 2) and prior to installing the threaded adapter (piece 8) and adapter locknut (piece 10).
- Note:**
- While installing the sleeve (piece 2) onto the piston rod, rotate the piston until the threads pass the O-Ring (piece 14). This will prevent the O-Ring from being damaged by the threads.
- 2 Hoses are to be fastened together using heat shrink tube, every two feet.
- Tag with part number and current revision code.
- Inspection requirements:
- A. Puller must be able to withstand 10,000 psi pressure.
 - B. Puller must cycle without hesitation.
 - C. Puller must be free of scratches.
 - D. Labels must be attached squarely, and must be free of bubbles.
- 5 Steel stamp model number in area indicated.

**Figure 6.4-1
Medium Brute -30 and -70 Variants Assembly Diagram**

6.5 MEDIUM BRUTE PARTS LIST BMB-10

**Table 6.5-1
Medium Brute BMB-10 Parts List**

Reference Number	Description	Part Number	Reference Information
1	Cylinder	2184-009	
2	End Cap	2136-004	
3	Housing	2350-003	
4	Sleeve	2349-001	
5	Tang Mandrel Adapter	BMB-CA-13	
6	Locknut Adapter	2422-001	
7	Barrel Adapter	3941-001	
8	Barrel	3939-001	
9	Air Return Plate	2836-003	
10	Cylinder Lockring	2120-002	2 each
11	Piston Assembly	2405-004	
12	O-Ring	1046-046	
13	O-Ring	1046-002	AN6227-17
14	O-Ring	1046-004	AN6227-28
15	Backup Ring	1046-003	MS28782-17
16	Backup Ring	1046-005	MS28782-28
17	Cap	3003-003	
18	Barrel Lockring	2120-005	
19	Handle Assembly	5211-006	
20	Air Hose Tubing	2638-022	
21	Air Hose Fitting	1047-056	
22	Air Hose Elbow	1047-057	
23	Air Hose Assembly (Female)	2106-002	
24	Air Hose Assembly (Male)	2106-001	
25	Hydraulic Hose Assembly	2107-001	
26	Heat Shrink Tube (3" long)	2638-001	
27	BMB Puller Label	1009-278	
28	FTI Label	1009-094	
29	"Do Not Strike" Label	1009-184	
30	Warning Label	1009-185	
31	Eye Protection Label	1187-106	
32	Ear Protection Label	1187-105	
33	Read Manual Label	1187-107	
34	CE Label	1166-001	
35	Spanner Wrench (not shown)	1045-100	Part not installed into Puller
--	Pressure Relief Tool	1187-770	Not included

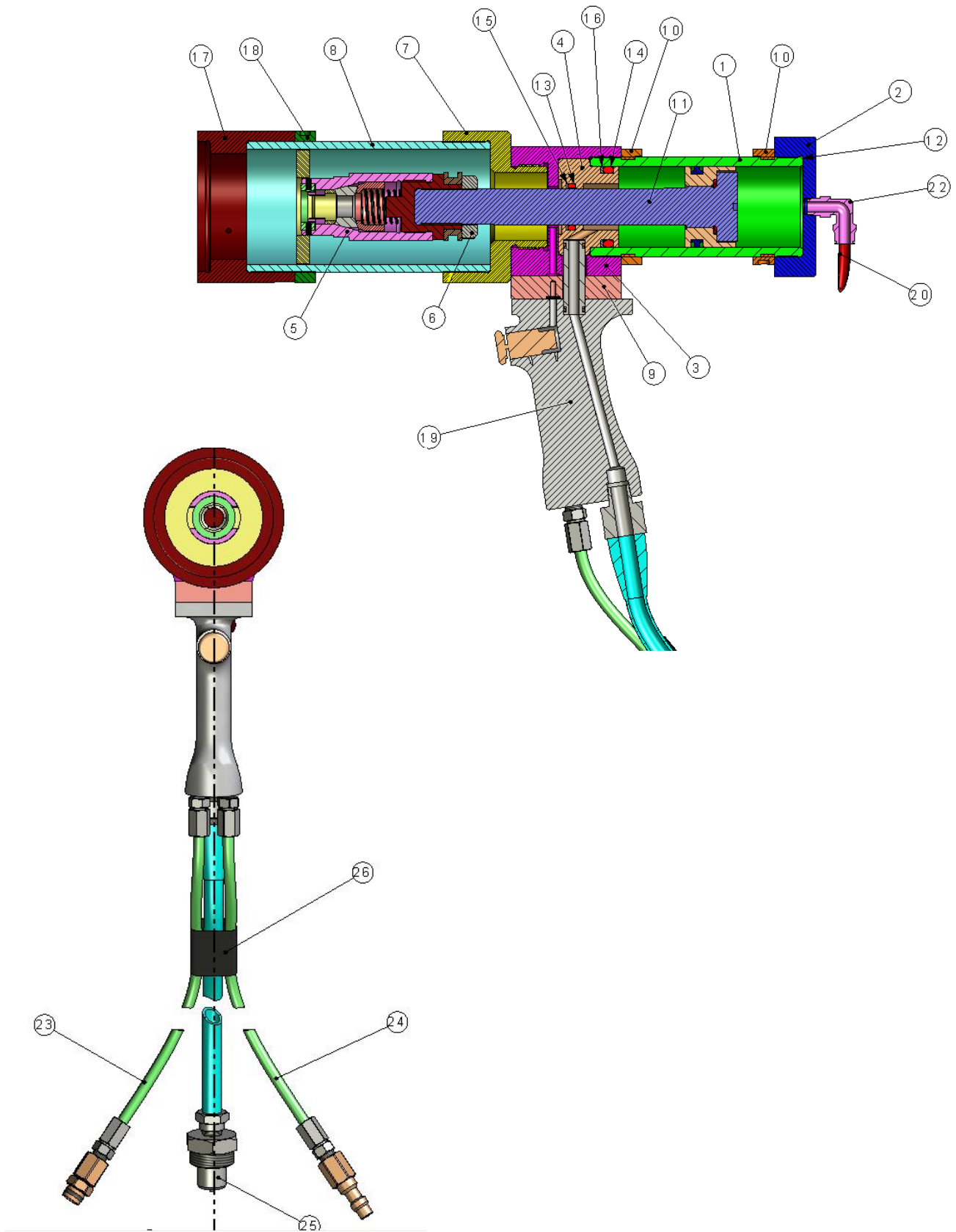

Figure 6.5-1
Medium Brute BMB-10 Assembly Diagram



FATIGUE TECHNOLOGY
401 Andover Park East
Seattle, Washington 98188-7605
USA

E.C. DECLARATION OF CONFORMITY

Manufacturer: Fatigue Technology
401 Andover Park East
Seattle, WA 98188-7605

Telephone: (206) 246-2010
Fax: (206) 244-9886

Responsible Person in E.C.: Jean-Michel Derisson
4 rue d'Austerlitz
31490 L guezin
FRANCE

Telephone: 33 5-34-559-916
Fax: 33 5-34-569-047

The undersigned declares that the machinery described:

Type:

Serial Number:

Conforms to the following directives:

- Council Directive 2006/42/EC (the Machinery Directive)
- EN 792-1 Hand-Held Non-Electric Power Tools – Part 1
- EN 982 Safety Requirements for Fluid Power Systems and Their Components – Hydraulics
- EN 983 Safety Requirements for Fluid Power Systems and Their Components – Pneumatics

and complies with the relevant health and safety requirements.

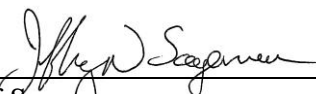

Jeff Sageman
Logistics Manager

February 23, 2016

Date

This page intentionally left blank for two-sided printing.