FATIGUE TECHNOLOGY OPERATIONS, MAINTENANCE, AND REPAIR MANUAL

Super Brute (SB-300A and SB-300B) Cylinder Puller Unit Revision E

FTI Part #2720-106

March 17, 2017



CE

Original Instruction

Fatigue Technology Inc. (FTI) is the supplier of Split Sleeve Cold Expansion™ (Cx™) systems to the aerospace industry worldwide. These proprietary systems and associated tooling may be covered by patents or agreements owned by, or exclusively licensed to, Fatigue Technology Inc. Use of tooling procured from other than a licensed source may constitute patent infringement.

The detailed tooling information in this manual was compiled and written by FTI. The tooling was designed specifically for use with FTI's Cx systems. FTI cannot be held responsible for damage or injury as a result of operating this equipment if it is used for other than the process intended, with any other tooling not provided by FTI, or not used in accordance with the instructions contained in this manual. To avoid personal injury, please observe all safety precautions and instructions. FTI reserves the right to change specifications or configurations of equipment detailed in this manual as part of our ongoing technical and product improvement programs. If you have any questions about the use or serviceability of this equipment, please contact our Sales Department.

FTI's systems and processes are the subject matter of one or more of the following patents: 4,809,420; 4,885,829; 4,934,170; 5,083,363; 5,096,349; 5,103,548; 5,127,254; 5,218,854; 5,245,743; 5,305,627; 5,341,559; 5,380,136; 5,405,228; 5,433,100; 5,468,104; 6,077,010; 6,183,180; 6,487,767; 6,792,657; 5,129,253; 513,898; 692015124; 581,385; 69310828; 468,598; 69105390; 643,231; 69414946; 696,686; 785,366; and other patents pending. These systems and processes are tooling critical and must be performed in accordance with FTI's specifications or controlling documents. To ensure proper results from FTI's cold expansion systems and to be licensed to use FTI's patented processes, it is essential that FTI's complete integrated system of tooling be purchased and utilized. The use of tooling purchased from other than a licensed supplier could jeopardize fatigue life enhancement and may constitute patent infringement.

ABOUT FATIGUE TECHNOLOGY INC.

Fatigue Technology Inc. (FTI) has provided innovative solutions to fatigue problems in metal structures since 1969. Complete systems of tooling are used worldwide to enhance the fatigue life of holes in airframes, turbine engines, and other critical structures.

The FTI staff of professionals provides a full range of support services including:

- Application engineering
- Detailed project planning, implementation, and management
- On-site assistance, including training and tool room setup
- Complete inventory allowing FTI to respond quickly to customer requirements

The Sales Department is always available to assist with special fatigue enhancement requirements. Please contact FTI with questions at any time.

TABLE OF CONTENTS

SECTION	DESCRIPTION	PAGE
Section 1	Introduction.....	1
1.1	About the Super Brute Cylinder Puller Units.....	1
1.2	General Description.....	1
1.3	General Specifications.....	2
Section 2	Safety	4
Section 3	Puller Unit Operating Instructions.....	6
3.1	Puller Unit Setup Procedure and Operation	6
3.2	Activation of Puller Unit	8
3.3	PowerPak Pressure Adjustment.....	8
Section 4	Puller Unit Maintenance	9
4.1	General Cleaning.....	9
4.2	Lubrication	9
4.3	Inspection	9
4.4	Disassembly.....	9
Section 5	Troubleshooting.....	10
Section 6	Illustrated Parts Breakdown.....	14
6.1	SB-300A and SB-300B Puller Unit Diagram.....	14
6.2	SB-300A and SB-300B Puller Unit Assembly Parts List	15
6.3	SB-300A and SB-300B Remote Trigger Assembly and Parts List.....	16

FIGURES

Figure 1.3-1	SB-300A and SB-300B Parts.....	2
Figure 1.3-2	SB-300A and SB-300B Dimensions.....	3
Figure 2.0-1	Safety Stickers	4
Figure 2.0-2	Location of Air Disconnect	5
Figure 3.1.1-1	SB-300A on Suspension System	6
Figure 3.1.1-2	Engine Leveler.....	6
Figure 3.1.2-1	Air-Hydraulic Hose Assembly.....	7
Figure 3.1.2-2	Trigger Assembly with Hoses.....	8
Figure 3.3-1	PowerPak Pressure Adjustment.....	8
Figure 5.1-1	FT-200 PowerPak	10
Figure 5.2-1	Hydraulic Quick Coupler.....	11
Figure 5.2-2	Hydraulic Hose Coupler	11
Figure 5.2-3	Enerpac CT-604 Pressure Relief Tool.....	11

TABLE OF CONTENTS (Continued)

SECTION	DESCRIPTION	PAGE
Figures (Continued)		
Figure 5.3-1	Trigger Response Valve.....	12
Figure 5.4-1	External Pressure Regulator Knob.....	13
Figure 6.1-1	SB-300A and SB-300B Diagram.....	14
Figure 6.3.1-1	Diagram of Remote Trigger Assembly.....	16
TABLES		
Table 1.3-1	SB-300A and SB-300B Specifications	3
Table 6.2-1	SB-300A and SB-300B Parts List.....	15
Table 6.3.1-1	Parts List for Cartridge Trigger Assembly Kit (FTI-CT-RK)	16
APPENDIX		
Appendix	E.C. Declaration of Conformity.....	17

SECTION 1: INTRODUCTION

This instruction manual contains information on the operation and maintenance of the Super Brute (SB-300A and SB-300B) Cylinder Puller Units. To obtain optimum performance and many years of trouble free service, operate the puller unit properly and carefully follow maintenance procedures.

Read this manual before operating the puller unit and retain it for future reference. If requested, FTI will provide this manual in the language of the end-user.

1.1 ABOUT THE SUPER BRUTE CYLINDER PULLER UNITS

The SB-300A and SB-300B Puller Unit is a powerful, heavy-duty tool specifically designed for use with all Fatigue Technology Inc. (FTI) Cold Expansion (Cx) processes. The SB-300A and SB-300B Puller Unit is designed to pull a mandrel through a hole with the pre-lubricated stainless steel split sleeves used in this process, or pre-lubricated bushing used in the ForceMate® (FmCx™) process.

The Super Brute Pullers have a maximum pull force of 300,000 pounds (1334.47kN) at 10,000 psi (68.95 MPa) pump pressure. The Super Brute is available for cold expanding holes over 4 inches (102mm) in diameter in aluminum, steel, and titanium. Please contact FTI technical support staff for application assistance.

The Super Brute will accommodate tooling for a material stack-up of approximately 6 inches (152mm).

The Super Brute has a fail-safe air control system that causes the puller retraction cycle to be interrupted whenever the operator releases finger pressure on the trigger or in the event of air or hydraulic hose failure. The puller unit operates in conjunction with FTI's FT-200 PowerPak air-hydraulic power units.

1.2 GENERAL DESCRIPTION

Hydraulic Fluid Requirements.....	U.S. MIL-H-5606, ISO 46
Operating Hydraulic Pressure.....	10,000 psi (68.95 MPa)
Pull Force Capacity.....	300,000 pounds (1334.47kN)
PowerPak Air Line Requirements.....	3/8-inch to 1/2-inch (9.5 to 12.7mm) inside diameter
PowerPak Air Flow Requirements.....	90 to 120 psi (0.62 to 0.82 MPa), 50 cfm (1.42m ³ /min)
Actuation.....	Pneumatic
Operation.....	Hydraulic
Compatible PowerPak.....	FT-200
Fail-Safe.....	Air logic safety circuit halts mandrel retraction when trigger is released
Weight without Tooling (SB-300A and SB-300B).....	360 pounds (163kg)*

*A user-supplied suspension system is required at the end use site. A risk analysis for the suspension is necessary to maintain compliance to end user's standards or directives. All risks involved with the suspension of the Super Brute Puller Units are the responsibility of the end user. User instructions and training regarding the suspension system are the responsibility of the end user.

1.3 GENERAL SPECIFICATIONS

The SB-300A and SB-300B Super Brute Puller Units are designed for applications where the capacity of the Super Brute SB-2A Puller Unit is exceeded. Refer to Figures 1.3-1 and 1.3-2 and Table 1.3-1 for specifications of the Super Brute Puller Units.

Tooling Selection: The mandrels and nose caps used with the SB-300A and SB-300B Puller Units are designed to the specific needs of the customer and the application requirements. Please contact FTI technical support staff for application assistance.

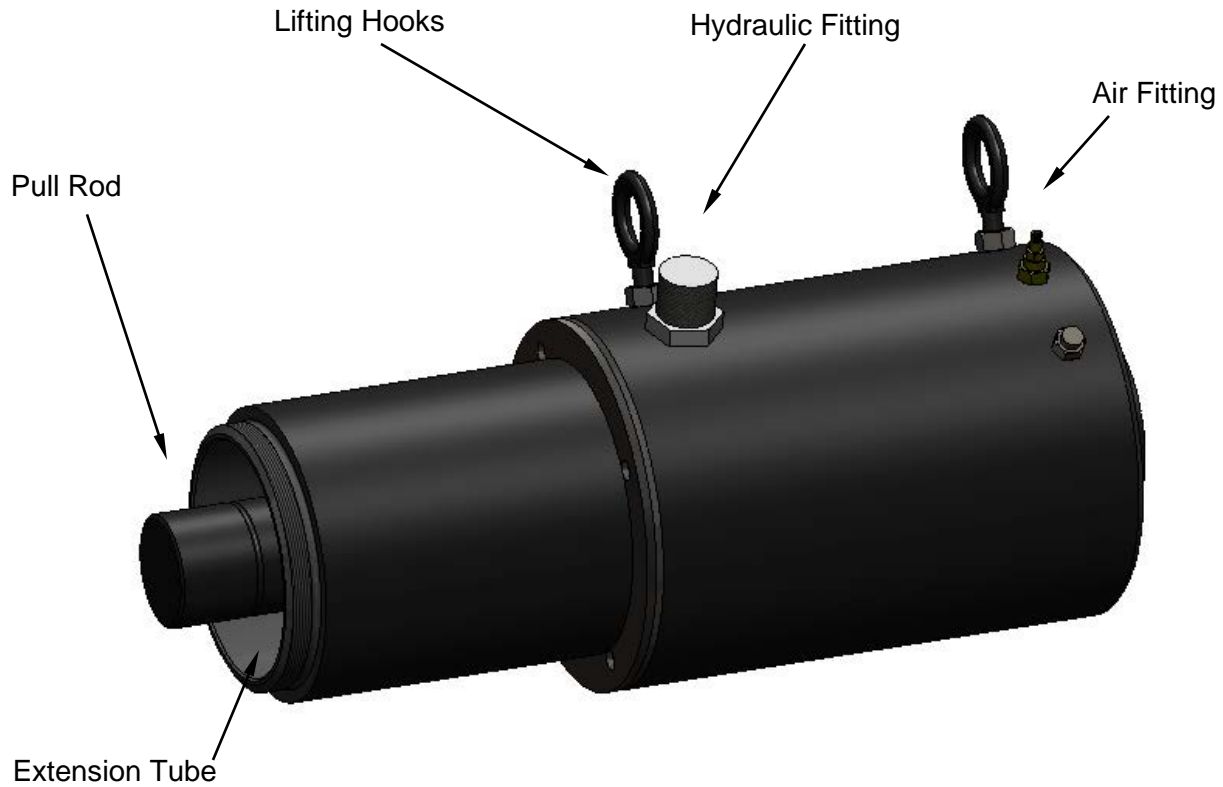

Figure 1.3-1
SB-300A and SB-300B Parts

**Table 1.3-1
SB-300A and SB-300B Specifications**

Model Number	Maximum Material Stack-up (inch)	Length (inch)	Stroke (inch)	Weight ² (lbs)
SB-300A	≈ 6 (152mm)	26.25 (667mm)	8.0 (203mm)	360 (163 kg)
SB-300B ¹	≈ 6 (152mm)	26.25 (667mm)	8.0 (203mm)	360 (163 kg)

Note 1: The difference between SB-300A and SB-300B is the threads on the pull rod.

Note 2: Puller unit only, does not include hoses or tooling.

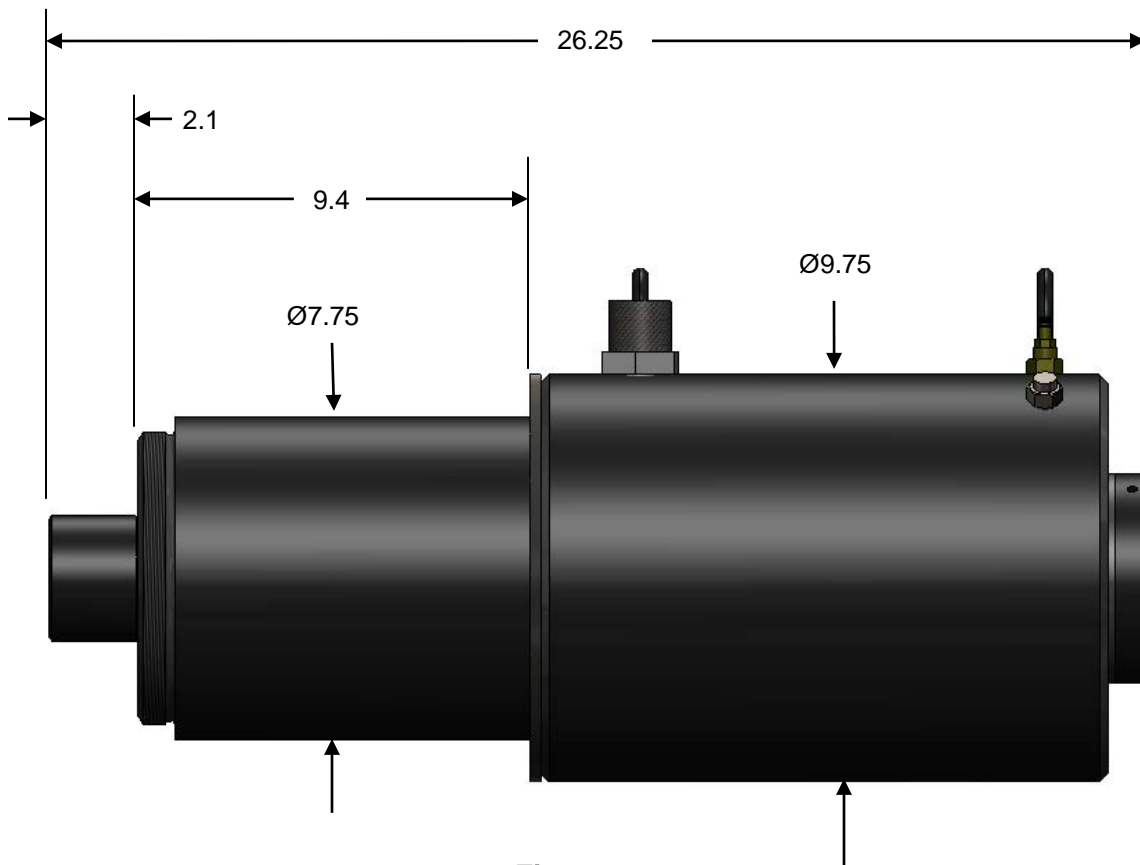

**Figure 1.3-2
SB-300A and SB-300B Dimensions**

SECTION 2: SAFETY

When used in accordance with these instructions, the puller unit is safe and easy to use. All general safety precautions associated with hydraulic and pneumatically operated power tools should be observed. Many of these are noted in this section.

The Super Brute Puller Units are not intended for hand-held operation. The Engine Leveler and carabineers are provided for ease of attachment to the operator's suspension system (see Section 3.1). A sling made from chain, cable, or strap with minimum load capacity certification is highly recommended. DO NOT use rope or other materials not intended for material handling.

The Super Brute Puller Units are only intended for use with the provided Engine Leveler attached to a suspension system. The suspension system is supplied by the end-user. The Engine Leveler, when used with a suspension system, provides stability to the Super Brute Puller Units. Any other operational position of the SB-300A or SB-300B, such as resting it on a platform or cart, could result in injury if the units are not properly secured to prevent rolling.

Ultimately, operators are responsible for their own safety; however, the following general safety precautions should be observed.

WARNING: HEAVY OBJECT – Mechanical lift only.

1. Operators must read this manual in its entirety before using the Super Brute Puller Unit. Eye and ear protection must be worn while operating the Super Brute. Follow the safety stickers on the Super Brute (see Figure 2.0-1).

Read manual before using



Always wear eye protection



Always wear ear protection



**Figure 2.0-1
Safety Stickers**

2. Remove from mechanical lift when servicing or performing maintenance.
3. Disconnect the air supply when:
 - Maintenance is to be performed.
 - Hydraulic hose is disconnected.
 - PowerPak is not in use.
4. Keep hands away from workpiece/Super Brute Puller Unit interface. A Remote Trigger Assembly (2049-007) is provided to allow a safe operating distance.

CAUTION: Operators must read this manual in its entirety before using the SB-300A Puller Unit. Eye and ear protection must be worn during operation.

5. In the event of a ruptured or leaking hydraulic hose, IMMEDIATELY RELEASE THE TRIGGER AND DISCONNECT THE AIR LINE at the air coupler from the PowerPak (see Figure 2.0-2). Never use your hands to grasp a leaking hose under pressure. The force of escaping hydraulic fluid could cause serious injury.
6. DO NOT attempt to disconnect the hydraulic hose while it is under pressure.
7. DO NOT expose hoses to potential hazards such as extreme heat or cold, sharp surfaces, or heavy impact.
8. DO NOT allow hoses to kink, twist, curl, or bend so tightly that the oil flow within the hose is blocked or reduced. Periodically inspect the hose for wear or damage that could cause premature failure of the hose and possibly result in injury. Damaged hoses must be replaced immediately.



**Figure 2.0-2
Location of Air Disconnect**

9. DO NOT use the hose to move attached equipment.
10. Hose material and coupler seals must be compatible with hydraulic fluid that meets the requirements of U.S. MIL-H-5606.
11. Hoses must not come in contact with toxic materials such as creosote-impregnated objects and some paints. Keep couplers and hoses clean and free of paint. Hose deterioration due to chemical degradation may cause the hose to fail under pressure. Damaged hoses must be replaced immediately.
12. Release the puller unit trigger when the mandrel clears the workpiece or becomes stuck.
13. Before operating the pump, make sure all hose connections are tightened securely. DO NOT over tighten.
14. Hose strain relievers must be placed around hose fittings during use. Damaged strain relievers must be replaced immediately.
15. Before operating the pump, tighten all hose connections using the proper tools. Do not over-tighten the connections. Connections need only be tightened securely and leak-free. Over-tightening may cause premature thread failure or high-pressure fittings to split at pressures lower than their rated capacities.
16. Inspect the hydraulic hose for signs of wear (cuts, abrasions or kinks) to the outer shell material. Pump clean oil through the entire length. Pressurize the hose and check for leaks at the crimped connectors, between the hose material and the fitting and between the fitting and the coupler.

IMPORTANT: FTI completed a risk assessment on this unit at our factory. Any modifications done by a third party or the final user are excluded from that risk assessment. As a result, modifications done by a third party or the final user nullify the CE marking.

SECTION 3: PULLER UNIT OPERATING INSTRUCTIONS

Become familiar with these instructions before operating the puller.

Check to ensure a sufficient working envelope for unobstructed operation. Note that during puller operation the backside of the puller (hex end) will extend up to the maximum stroke limit.

3.1 PULLER UNIT SETUP PROCEDURE AND OPERATION

3.1.1 Lifting the SB-300A and SB-300B

An Engine Leveler with carabineers is supplied for attachment to a suspension system. When operating the SB-300A and SB-300B it is intended for use with the supplied Engine Leveler.

1. Attach the Hoist Link to a suspension system (see Figures 3.1.1-1 and 3.1.1-2).
2. Attach the carabineers to the eye hooks on the Super Brute unit (see Figures 3.1.1-1 and 3.1.1-2).
3. Lift the Super Brute slowly, stopping to use the manual crank for weight balance adjustment (see Figures 3.1.1-1 and 3.1.1-2).
4. Ensure stability of the suspension system.

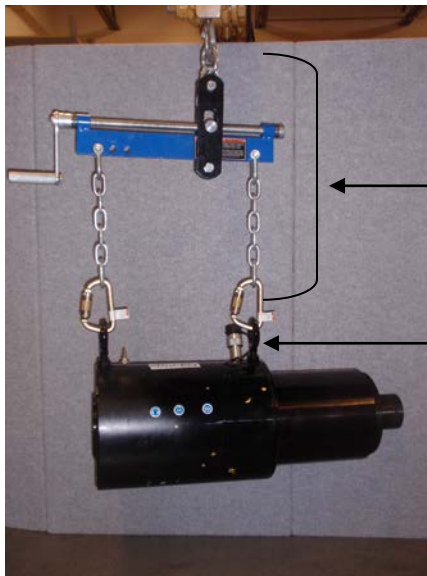

**Figure 3.1.1-1
SB-300A on Suspension System**

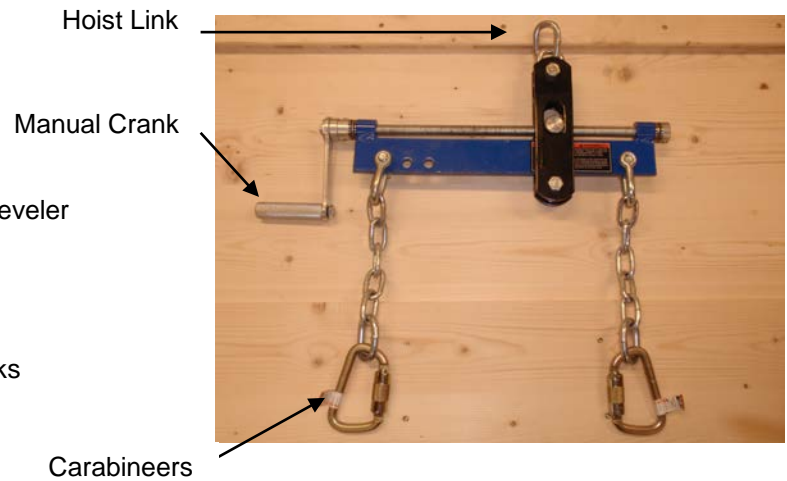

**Figure 3.1.1-2
Engine Leveler**

3.1.2 Inspecting / Preparing the SB-300A and SB-300B

Refer to Section 6 (Illustrated Parts Breakdown) for parts identification.

1. Inspect all threads and fittings for signs of wear or damage and replace them if necessary.
2. Remove the protection sleeve on the pull rod and inspect the threads.
3. Test shop air to ensure that air is clean, dry, and between 90 and 120 psi (0.62 and 0.82 MPa) at 50 cfm (1.42m³/min).
4. Uncoil the air-hydraulic extension hose assembly and inspect all threads, couplings, and hoses for damage and degradation. Any damaged component must be replaced immediately.
5. Remove thread protectors from the hydraulic fittings and thread the hydraulic hose fitting from the hose assembly (male) onto the hydraulic fitting of the puller unit. Wipe fittings clean prior to connecting. Make sure to thread couplers completely together. There should be positive contact between the coupler and the hose-fitting flange (you should not be able to insert a piece of paper between the coupler and the hose fitting flange—see Section 5, Problem 2 for more information). Failure to completely tighten the coupler will prevent the puller from returning to the forward (start) position. Strain relievers must be placed on hose fittings during operation. If strain relievers are worn or damaged, they must be replaced immediately.
6. Connect the female air quick disconnect onto the male fitting of the puller unit.
7. Remove thread protectors from the hydraulic fittings and thread the hydraulic hose fitting from the hose assembly (male) onto the hydraulic fitting of the FTI PowerPak (female). Wipe fittings clean prior to connecting. Make sure to thread couplers completely together. Failure to do so will prevent the puller from returning to the forward (start) position. Strain relievers must be placed on hose fittings during operation. If strain relievers are worn or damaged, they must be replaced immediately.
8. Connect the male air quick disconnect attached to the T-fitting into the female coupler of the FTI PowerPak. See Figure 3.1.2-1.

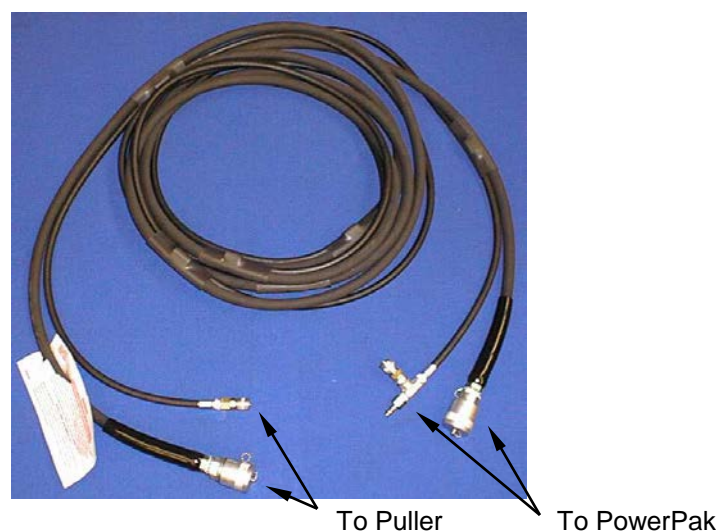

Figure 3.1.2-1
Air-Hydraulic Hose Assembly

9. Uncoil the trigger assembly and inspect all threads, couplings and hoses for damage and degradation. Any damaged component must be replaced immediately.
10. Connect the female air quick disconnect of the trigger assembly hose to the male fitting of the FTI PowerPak.
11. Connect the male air quick disconnect into the female coupler at the T-fitting of the air-hydraulic extension hose assembly. See Figure 3.1.2-2.
12. Connect the female quick disconnect of a 1/2-inch (12.7mm) inside diameter (ID) shop air line onto the male air inlet of the PowerPak.



**Figure 3.1.2-2
Trigger Assembly with Hoses**

3.2 *ACTIVATION OF PULLER UNIT*

1. The puller can be activated only when connected to the FTI PowerPak.
2. Activate puller by depressing the trigger on the handle. Hydraulic pressure is transmitted through the hose to the cylinder of the puller, which then retracts the hydraulic piston that performs the cold expansion procedure.
3. Releasing the trigger changes pressure at the pilot valve and stops the pull cycle. Air pressure returns the puller to original position.
4. If the puller fails to operate as detailed above, refer to Section 5 (Troubleshooting).

3.3 *POWERPAK PRESSURE ADJUSTMENT*

1. Activate the puller as described above. Hold the trigger until the PowerPak attains peak pressure; release the trigger two seconds after the peak pressure is reached.
2. If the pressure does not reach 10,000 psi (68.95 MPa), adjust the PowerPak external pressure regulator:
 - a. Squeeze the trigger to activate the puller unit.
 - b. Loosen the locknut and turn the hydraulic pressure valve clockwise until the pressure reaches 10,000 psi (68.95 MPa).
 - c. Tighten the locknut to secure.



**Figure 3.3-1
PowerPak Pressure Adjustment**

SECTION 4: PULLER UNIT MAINTENANCE

The puller requires routine checking and periodic preventative maintenance to ensure safe, trouble-free operation. No special maintenance is required. The following maintenance actions are suggested.

CAUTION: Before attempting any maintenance operations on the puller unit, disconnect the PowerPak from the air supply or disconnect the puller unit from the PowerPak or hand pump.

4.1 GENERAL CLEANING

1. Periodically clean the outer surfaces of the puller unit and PowerPak.
2. When not in use, ensure thread protectors are reinstalled on the hydraulic fittings and the pull rod.
3. Keep all hose connections free of dirt and grime; doing so will dramatically extend the life of pumps and puller seals.

4.2 LUBRICATION

1. There is no internal lubrication requirement for the puller unit.
2. Whenever the puller is to be stored for any length of time, maintain a thin coat of 10-weight oil on the outside of black oxide surfaces.

4.3 INSPECTION

Periodically inspect threaded fittings, hoses, and strain relievers for cracks, leaks, or other damage. Repair and replace immediately.

4.4 DISASSEMBLY

The Super Brute Puller Units are not intended for repair or disassembly in the field. In the event of hydraulic fluid leakage around the seals, the puller unit should be returned to FTI. Please contact FTI technical support staff for assistance.

SECTION 5: TROUBLESHOOTING

This section provides solutions to some basic problems. If you cannot solve your operational problems with the information provided in this section, please contact your nearest FTI representative.

NOTE: Should difficulties originate in the PowerPak, consult the specific PowerPak Operations, Maintenance and Repair Manual. Remember, always disconnect the PowerPak main air supply before performing any repair or maintenance.

PROBLEM	CAUSE	SOLUTION
1. PowerPak will not build full hydraulic pressure.	(a) One or more of the key air or hydraulic lines has not been securely connected.	(a) Check the following hose connections: <ol style="list-style-type: none"> (1) Main air line quick disconnect fitting from shop air system to PowerPak. (2) Hydraulic quick couplings connecting the hoses to the PowerPak manifold and the puller to the hydraulic hoses. See Figure 5.1-1. (3) Two male/female air line quick disconnect fittings connecting the puller and trigger to the PowerPak manifold.
	(b) Inadequate external pressure.	(b) Adjust external pressure regulator.
	(c) Inadequate air supply.	(c) Check the main air supply has not been interrupted and meets minimum flow requirements (90 psi (0.62 MPa), 50 cfm (1.42m ³ /min)).

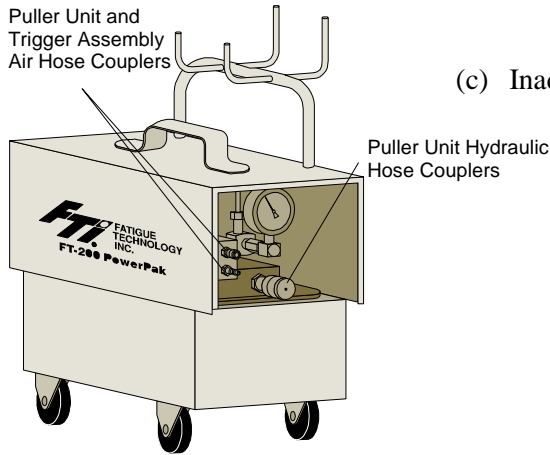

Figure 5.1-1
FT-200 PowerPak

CAUTION: Hydraulic oil under extreme pressure may cause serious injuries if not handled carefully. For technical assistance, please contact FTI's technical support staff.

PROBLEM**CAUSE****SOLUTION**

2. Puller retracts on first trigger actuation but will not return to start position
- (b) **AND** the hydraulic hose is difficult to bend or coil (indicating unrelieved pressure built up in the hose).

- (a) The new puller unit requires lubrication through the piston and cylinder.
- (b) The hydraulic quick coupler line has not been completely tightened at the PowerPak manifold. (There should be no space between the PowerPak couple and the hose fitting flange. See Figure 5.2-1.)

- (a) Cycle the trigger several times to introduce hydraulic fluid into the cylinder.
- (b) Once hydraulic pressure has been introduced to the hydraulic hose, the pressure must be relieved before the coupler can be sufficiently tightened.

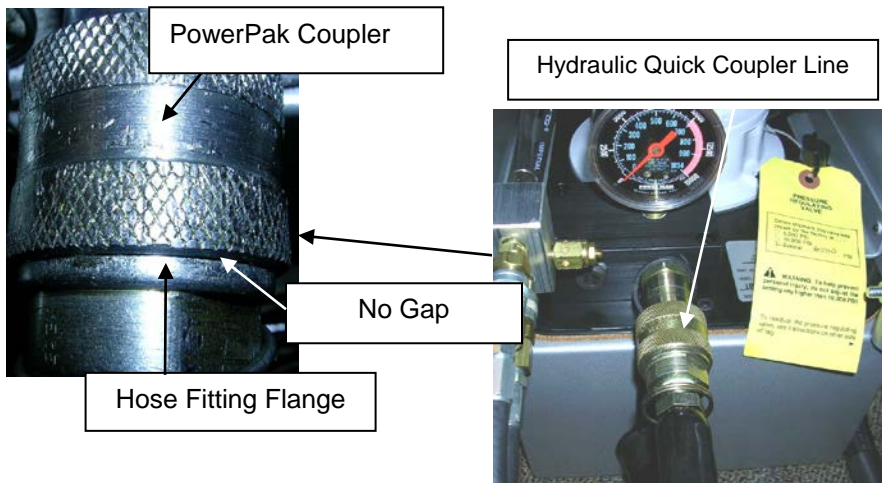

Figure 5.2-1
Hydraulic Quick Coupler

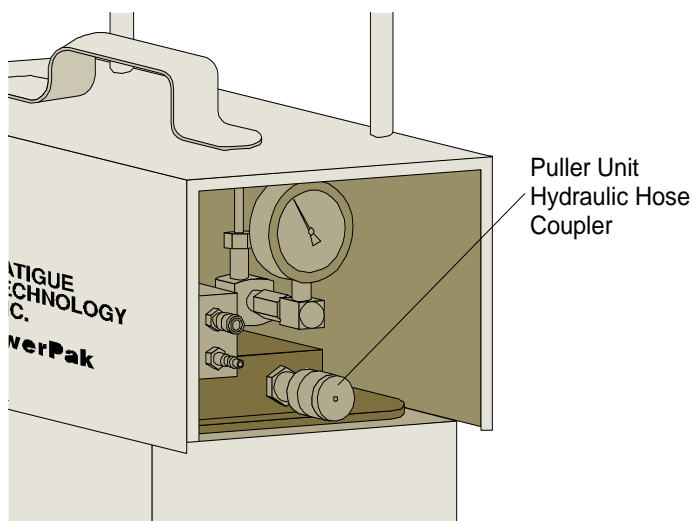

Figure 5.2-2
Hydraulic Hose Coupler



Figure 5.2-3
Enerpac CT-604 Pressure Relief Tool

Procedure for relieving hydraulic pressure:

- (1) Disconnect the main air supply.
- (2) Disconnect coupler from PowerPak (Figure 5.2-2).
- (3) Connect Enerpac CT-604 to the coupler and bleed off hydraulic oil to relieve the built-up pressure. The Enerpac CT-604 Pressure Relief Tool is shown in Figure 5.2-3.
- (4) Once pressure is relieved, coupler may be tightened and reinstalled onto the PowerPak.
- (5) Reattach air lines to get the puller to return.
- (6) Check oil level in the PowerPak reservoir.

PROBLEM**CAUSE****SOLUTION**

3. PowerPak will not generate constant pressure (or hiccups).

(a) Trigger response valve requires adjustment. See Figure 5.3-1.

(a) Adjustment procedure:

- (1) Loosen the locknut on the trigger response valve.
- (2) Using a screwdriver, open screw counterclockwise until the PowerPak will not start when the puller trigger is depressed.
- (3) Turn screw clockwise until:
 - The PowerPak generates constant pressure when the puller trigger is depressed, and
 - The PowerPak starts instantly when the puller trigger is depressed and stops instantly when released. When the puller trigger is depressed, the PowerPak should be run at the pre-set pressure until the trigger is released.
- (4) Hold set screw in position and tighten the locknut until snug.

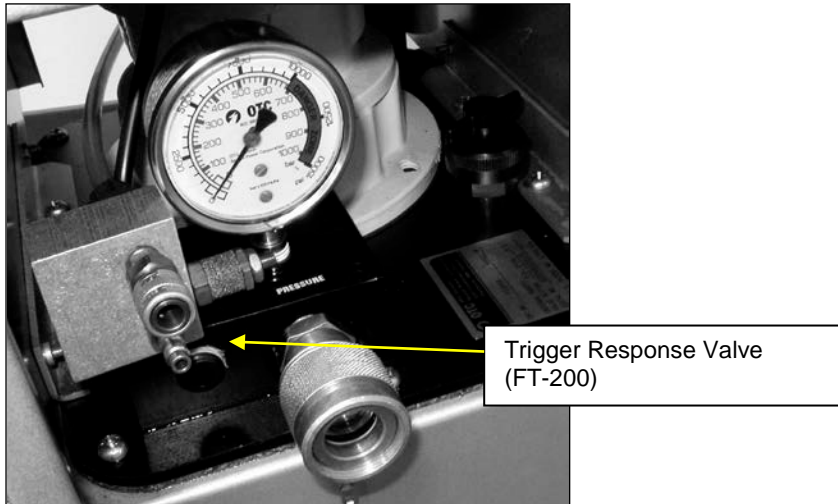

Figure 5.3-1
Trigger Response Valve

(b) Inadequate air supply.

(b) Check main air flow for 90 psi (0.62 MPa), 50 cfm (1.42m³/min).

PROBLEM**CAUSE****SOLUTION**

4. PowerPak will not operate or maintain sufficient pressure (10,000 psi (68.95 MPa)).

(a) Hydraulic pressure requires adjusting. See Figure 5.4-1.

- (a) Adjust PowerPak pressure valve:
- (1) Squeeze the trigger on the puller unit to activate the PowerPak.
 - (2) If pressure does not reach 10,000 psi (68.95 MPa), loosen the locknut and turn the hydraulic pressure control clockwise until pressure reaches 10,000 psi (68.95 MPa).
 - (3) Tighten locknut to secure.

(b) Inadequate air supply.

(b) Increase pressure or flow of available shop air.

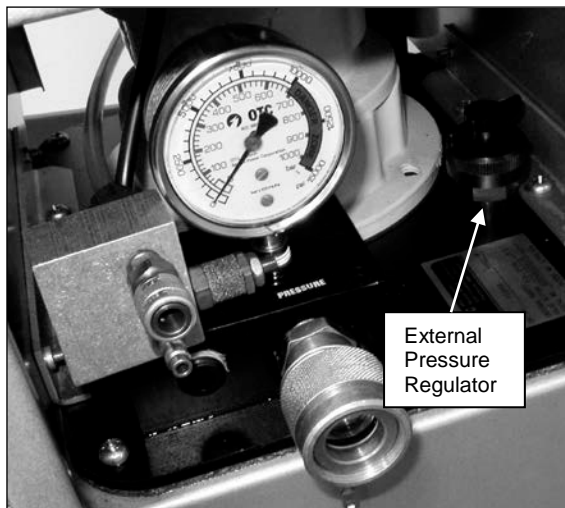

Figure 5.4-1
External Pressure Regulator Knob

- If the PowerPak will not generate or maintain sufficient pressure, the main air line pressure is too low or the PowerPak hydraulic pressure requires adjustment.
- Air pressure requirements: 1/2-inch (12.7mm) ID air line with 90 to 120 psi (0.62 to 0.83 MPa).
- Flow requirements: 40 to 50 cfm (1.13 to 1.42m³/min).

SECTION 6: ILLUSTRATED PARTS BREAKDOWN

6.1 SB-300A AND SB-300B PULLER UNIT DIAGRAM

A diagram of the SB-300A and SB-300B Puller Units is shown in Figure 6.1-1, which corresponds to the parts list in Table 6.2-1.

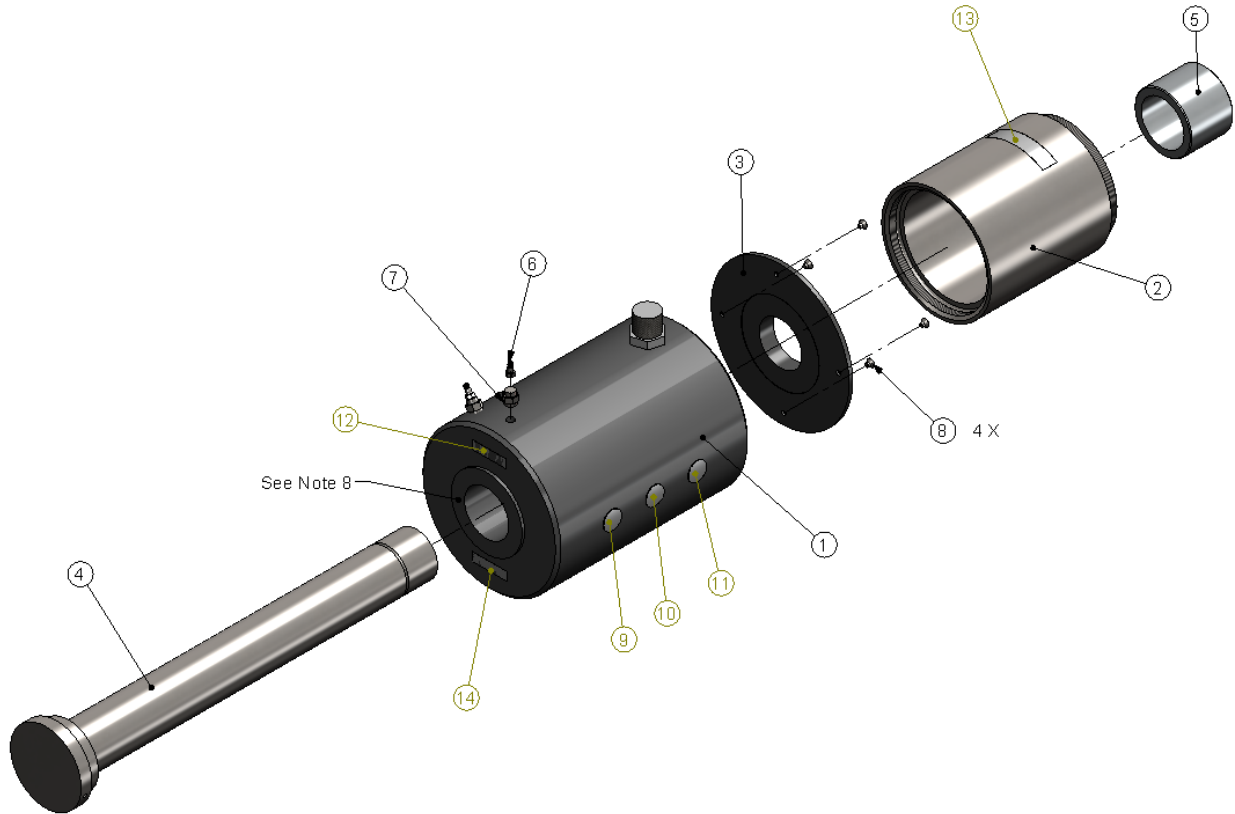

Figure 6.1-1
SB-300A and SB-300B Diagram

6.2 SB-300A AND SB-300B PULLER UNIT ASSEMBLY PARTS LIST

The parts list in Table 6.2-1 corresponds to the drawing in Figure 6.1-1 on the previous page.

**Table 6.2-1
SB-300A and SB-300B Parts List**

Reference Number	Description	Part Number	Notes
1	Modified Cylinder, SB-300	6350-001	
2	Tube, SB-300A Extension	6293-002	
	Tube, SB-300B Extension	6293-001	
3	Faceplate, SB-300	6291-001	
4	Pull Rod, SB-300A	6172-001	
	Pull Rod, SB-300B	6172-002	
5	Shipping Collar	6338-001	
6	Male Quick Disconnect Coupler	1047-036	
7	3/8 to 1/8 Pipe Bushing	1047-029	
8	Screw, FHC 1/4-28UNC x 5/8"	1036-019	
9	Ear Protection Label	1187-105	
10	Eye Protection Label	1187-106	
11	Read Manual Label	1187-107	
12	Warning Label	1009-258	
13	Caution Label	1009-242	
14	Do Not Strike Label	1009-184	
---	Polyethylene Mesh Sleeving	1187-104	1
---	Air-Hydraulic Hose Extension Assembly	5628-001	1
---	Trigger Assembly	2049-007	1
---	Engine Leveler with Handle	1199-255	1
---	Carabineer, Gate Opening 1 inch	1199-254	1
---	Case	1199-257	1
---	Enerpac CT-604 Pressure Relief Unit	1187-770	1, 2

Note 1: Not shown in assembly illustration.

Note 2: Not included.

6.3 SB-300A AND SB-300B REMOTE TRIGGER ASSEMBLY AND PARTS LIST

6.3.1 SB-300A and SB-300B Remote Trigger Assembly

Fatigue Technology Inc. has redesigned the remote trigger assemblies to a cartridge trigger assembly. The new design will reduce the occurrence of trigger air leaks, perform more reliably (better pump actuation), and is easier to maintain. As of June 2005, all remote triggers will have the cartridge trigger assembly.

The previous aluminum trigger design can be easily replaced with this improved brass trigger assembly. Two part numbers are needed for replacement:

- The Cartridge Trigger Assembly Kit (FTI-CT-RK)
- Puller Trigger Rework Tool Kit (FTI-CT-RKT)

One FTI-CT-RK is required for each puller converted. Only one FTI-CT-RKT is required regardless of the number of remote triggers converted. The FTI-CT-RKT kit includes the tools (punch, tap, etc.) required and detailed instructions on how to perform the modification.

Table 6.3.1-1 shows the parts list that corresponds to Figure 6.3.1-1.

**Table 6.3.1-1
Parts List for Cartridge Trigger Assembly Kit (FTI-CT-RK)**

Quantity	Line Item	Description	FTI Part Number	Included in Kit #
1	1	Valve, Cartridge Trigger	1187-622	FTI-CT-RK
1	2	Spring, LB Handle	1187-623	FTI-CT-RK
1	3	Retainer, LB Handle	1187-624	FTI-CT-RK
1	4	Sleeve, Puller Handle	3196-001	FTI-CT-RK
1	5	Guard, Remote Trigger Handle	5193-001	None
2	6	Screw, 8-32UNC Modified, 3/16" Long	1199-329	None

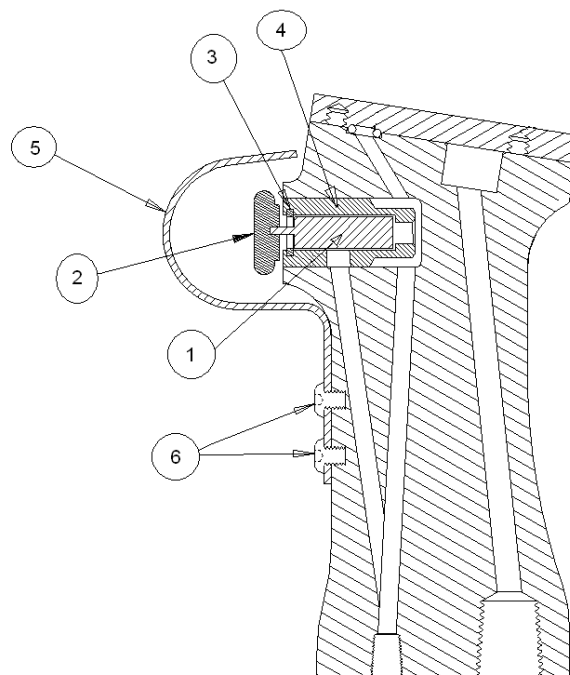

**Figure 6.3.1-1
Diagram of Remote Trigger Assembly**

Appendix
E.C. Declaration of Conformity

This page intentionally left blank for two-sided printing.



FATIGUE TECHNOLOGY
401 Andover Park East
Seattle, Washington 98188-7605
USA

E.C. DECLARATION OF CONFORMITY

Manufacturer: Fatigue Technology
401 Andover Park East
Seattle, WA 98188-7605

Telephone: (206) 246-2010
Fax: (206) 244-9886

Responsible Person in E.C.: Jean-Michel Derisson
4 rue d'Austerlitz
31490 Léguevin
FRANCE

Telephone: 33 5-34-559-916
Fax: 33 5-34-569-047

The undersigned declares that the machinery described:

Type:

Serial Number:

conforms to the following directives:

Council Directive 2006/42/EC (the Machinery Directive)

and complies with the relevant health and safety requirements.

Jeff Sageman
Logistics Manager

January 17, 2014

Date

This page intentionally left blank for two-sided printing.